



1928

K.N. Toosi University of Technology

PIPRO

Petroleum Industry Productivity Research Center



www.PIPRC.kntu.ac.ir

PIPRO Petroleum Industry Productivity Research Center

K.N. Toosi University of Technology.

Iran, Tehran Province, Tehran, Mirdamad Blvd, No. 470

Tel: +98(21)88881002, Fax: +98(21)88882997

Email: piprc@kntu.ac.ir

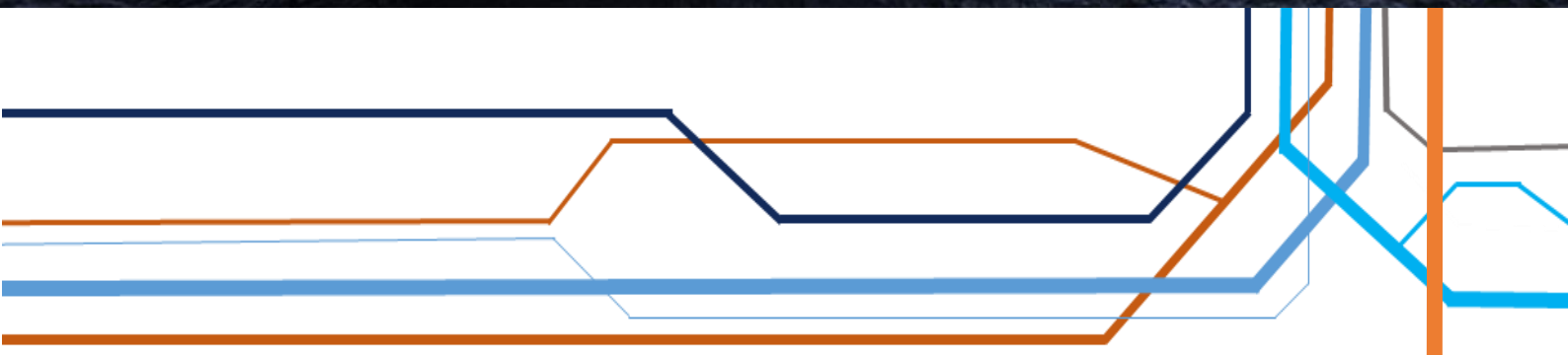

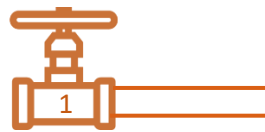

Table of Contents

Mission of the Petroleum Industry Productivity Research Center	2
.....	3
PART I: Research Groups.....	3
The Exploration and Optimal Development of Oil and Gas Reservoirs Research Group	5
The Energy and Environment Research Group.....	6
The Oil, Gas and Petrochemical Processing Research Group	7
PART II: Projects	9





Mission of the Petroleum Industry Productivity Research Center

Petroleum has been the leading industry worldwide for more than 100 years. Any improvement in oil and gas production and consumption will have a significant effect on other industries and our lives at large. With the aim of improving quality and quantity within the Iranian petroleum industry, the Petroleum Industry Productivity Research Centre (PIPRC) has been established at the K.N. Toosi University of Technology (KNTU). KNTU is a leading university in industrial research and development. With more than 80 years of experience in engineering education, research and industrial connections, KNTU has established a close relationship with the petroleum industry. Relying on extensive experience in the oil and gas industry, the PIPRC aims to further improve advanced applied research within KNTU and to extend the university's role in the petroleum industry.

The following areas are within the interest of the PIPRC:

- Examining the geoscience and geomatics of oil and gas reservoirs to improve oil processing
- Considering the chemical properties of produced oil and gas to enhance downstream processing
- Implementing geomechanical modeling of oil and gas reservoirs
- Conducting data mining and designing advanced control and automation systems
- Researching the environmental impact of the petroleum industry
- Utilizing greener EOR/IOR technologies.

The PIPRC engages distinguished professors and researchers from various departments of KNTU, including geomatics and geoscience, civil engineering, mechanical engineering, electrical engineering, computer engineering, chemistry, mathematics, and physics. Many renowned petroleum industry experts are adjunct members of the PIPRC, and close relations are maintained with both domestic and international companies in the petroleum industry. Consequently, the PIPRC has become a leading research center in the petroleum industry, with the capability of supplying advanced research and solutions.



PART I: Research Groups





The Exploration and Optimal Development of Oil and Gas Reservoirs Research Group

The Exploration and Optimal Development of Oil and Gas Reservoirs (EODR) research group focuses on the exploration program and static/dynamic reservoir analysis and code development. The EODR research group aims to design and implement a GIS-based model to determine high-potential areas for hydrocarbon reservoirs and to provide multiscale and coupled models for analyzing rock, pores and fluids from diverse sources, with various scales from micro to mega. Thanks to a multidisciplinary set of

scientists, with backgrounds in civil, mechanical, electrical, geomatics and environmental engineering as well as chemistry, the EODR research group specializes in the management of mature oil and gas fields and the development of new fields, while concentrating on the big picture and integrated modeling of the reservoir. The EODR research group has a keen interest in intelligent completions, including local or remote monitoring, evaluating and actively managing production or injection in real time without any good interventions.

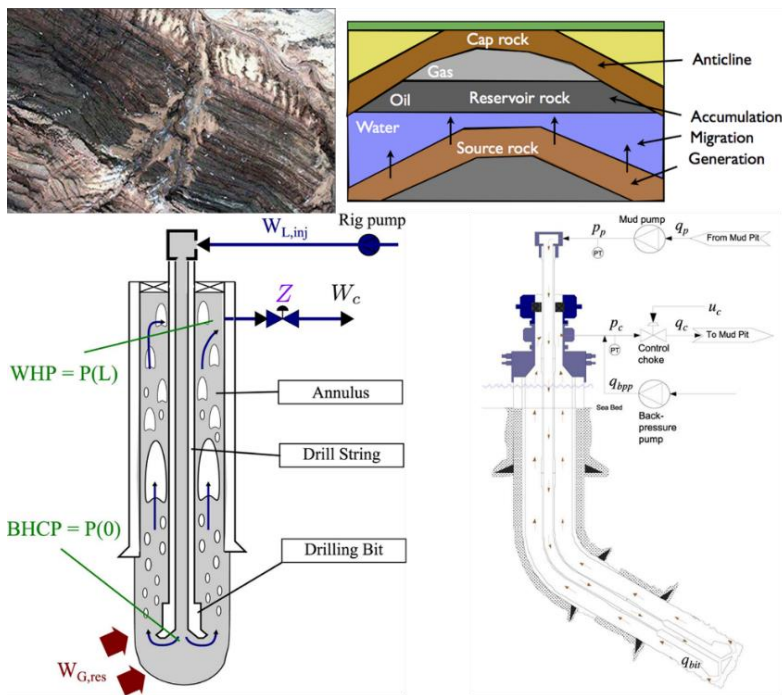



The Energy and Environment Research Group

The Energy and Environment (E&E) research group focuses on increasing the efficiency of the production and consumption of the oil and gas sector while keeping the environment cleaner. In addition to valuable equipment, the group takes advantage of a multidisciplinary set of scientists with a wide range of expertise, including mechanical engineering, electrical engineering, geomatics engineering and chemistry. The first objective of the group is to increase energy efficiency through tested industrial solutions. The energy efficiency measures designed by the group are for both upstream and downstream usage.

Highly volatile oil prices make it necessary to assure the lowest possible operational energy costs for the extracted oil or gas. We also offer solutions for aging oil and gas wells, with the objective to decrease the cost of oil and gas extraction. The second aim of the group is to offer environmental solutions for the oil and gas sector. The group members have a wide range of innovative measures to monitor and reduce emissions and to maintain cleaner fossil fuel production and consumption. We also have strong track records of successful industrial projects, in addition to publications in highly reputable international journals.

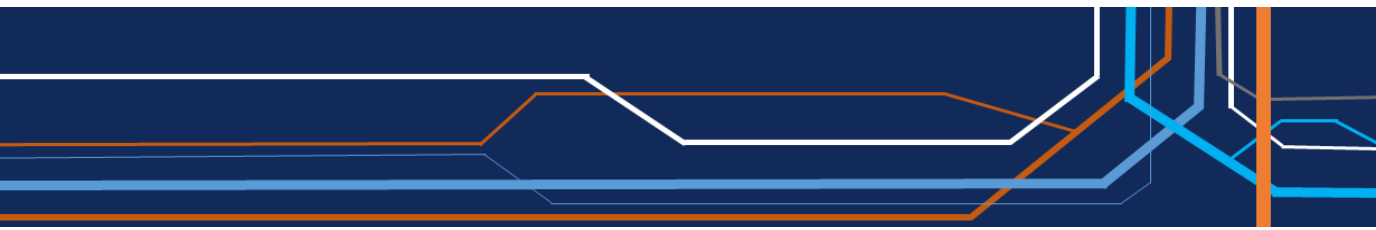

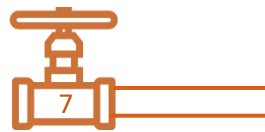

The Oil, Gas and Petrochemical Processing Research Group

The Oil, Gas and Petrochemicals Processing (OGPP) research group focuses on the systematic study of oil extracted from the country's oil fields and the evaluation of products that may be extracted and processed, taking into account economic considerations and the variety of technical knowledge available in the country. The OGPP also provides consultancy services to oil field equipment designers to ensure the construction of stable and suitable equipment that will be in contact with oil

compounds. Another objective of this group is the development of new methods for optimizing the processing of oil, gas and petrochemicals with regard to considerations of petroleum compounds. This research group has a keen interest in the design and construction of advanced control and monitoring systems in the production processes of petroleum products, as well as the analysis of petroleum industry data and metadata for optimizing the process of oil and gas production.

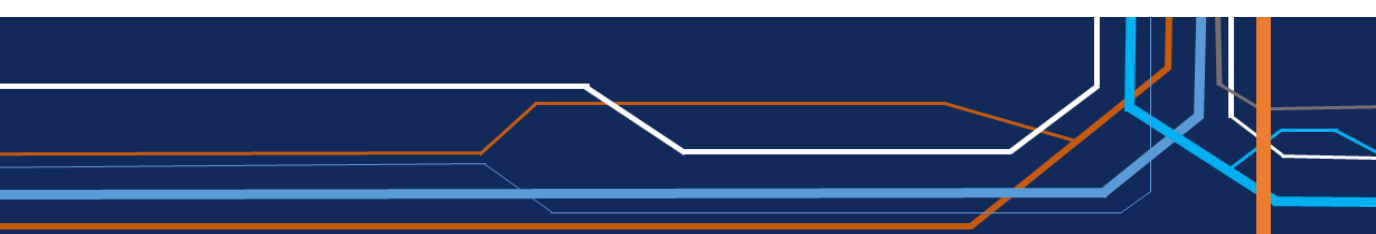

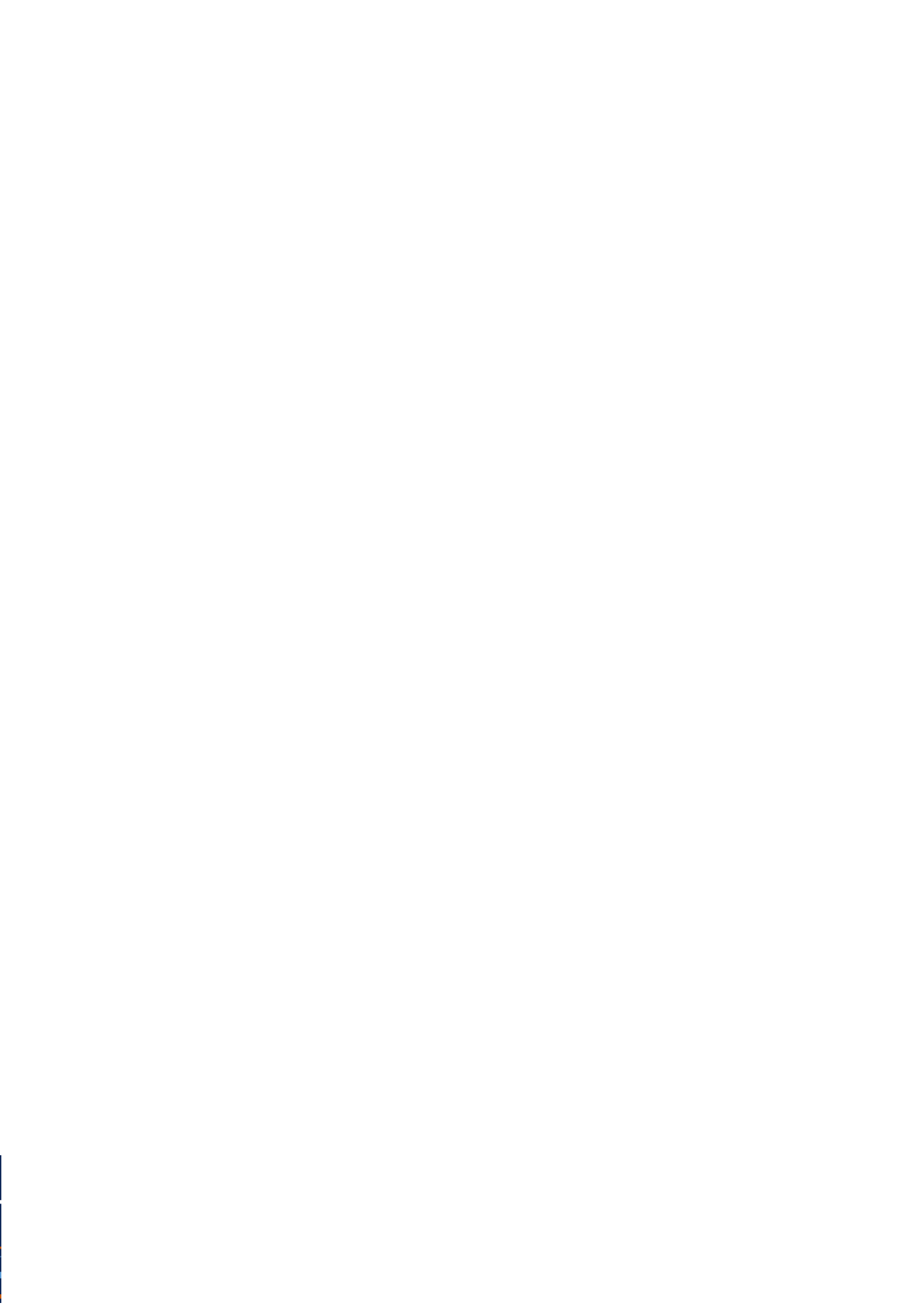



PART II: Projects



Note: The projects that are introduced in this section are either conducted in KNTU or other institutes by the PIPRC members.

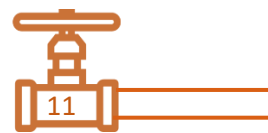

Supervisor of Iranian National Intelligent Pipeline Instrumentation Gauges (PIG)

Client: National Iranian Gas Company (NIGC)

Date: 2015

Project Director: Dr. Hamid D. Taghirad

Project associate members: Dr. Ahmad Reza Tahsiri, Dr. Mohammad Ali Nekouei, Dr. S. Ali A. Moosavian, Dr. Ali Ghaffari.

Project type: Supervision

Project collaborator: K.N. Toosi University of Technology (KNTU) & Segal Pardazesh Engineering Company

Summary of project:

Pigging in the context of pipelines refers to the practice of using devices known as Pipeline Instrumentation Gauges “PIG” to perform various maintenance operations. This is done without stopping the flow of the product in the pipeline. These operations include but are not limited to cleaning and inspecting the pipeline. Pigging has been used for many years to clean large diameter pipelines in the oil industry. Today, however, the use of smaller diameter pigging systems is now increasing in many continuous and batch process plants as plant operators search for increased efficiency and reduced costs. There are four main uses for pigs:

- Physical separation between different fluids flowing through the pipeline

- Internal cleaning of pipelines
- Inspection of the condition of pipeline walls (also known as an Inline Inspection (ILI) tool)
- Capturing and recording geometric information relating to pipelines (e.g., size, position).

Since April 2015, Aras Intelligent PIG Research Group has started a collaboration with research and development department of National Iranian Gas Company (NIGC) as the supervisor of Iranian national intelligent PIG project. This project is one of the ten crucial national projects that Iranian Oil ministry has focused on. Segal Tech Company is the engineering and procurement party of the project which has to design, supply all equipment and integrate them to provide three types of intelligent PIG namely High-Resolution MFL, High-Resolution TFI, and the Calliper.



Each of these intelligent PIGs consists of several major subsystems such as electronic and mechanical, signal processing and software for displaying the pipeline defects. Aras Intelligent PIG Research Group closely monitor and control the progression of this national

project, as well as provides technical consultations to Segal Tech. The project has accomplished its design, manufacturing, assembly and pull through tests so far, and is in its final stage of approval.



A typical Intelligent PIG device



Iranian National MFL PIG



Iranian National TFI PIG



Iranian National Calliper (EGP) PIG



Development and design of spatial data infrastructure of Iranian Gas Transmission Company

Client: Iranian Gas Transmission Company

Date: 2010-2011

Project Director: Dr. Mohammad Karimi and Dr. Ali Mansourian

Project associate members: Dr. Mohammad Javad Valadan Zoej, Dr. Hamid Ebadi, and Dr. Mohammad Taleai

Project type: Feasibility study and design

Project collaborator: K.N. Toosi University of Technology (KNTU)

Summary of project:

The Iranian Gas Transmission Company (IGTC) signed a contract with K N Toosi University of Technology to perform a research project on the development and design of Spatial Data Infrastructure (SDI) for IGTC. In this project, after giving a comprehensive description about the current status of the central department of IGTC and some of the regional operational branches, from organizational duties, spatial and attribute data, technological information, and their human resources

perspectives the existing status of the company from SDI point of view was analyzed and summarized. The major outputs of this projects are includes:

- Assessment and Requirement Analysis
- Conceptual model and Standard of Spatial Database
- Metadata standard for spatial database
- Operational routines for spatial data management

Definition of requirement projects and activities for GIS and SDI.

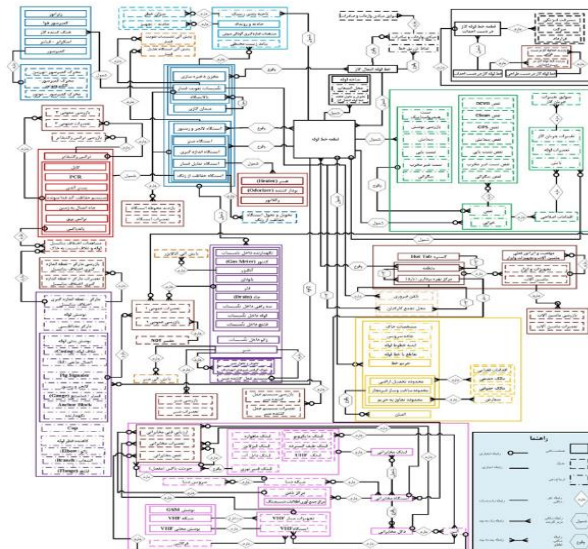

Hydrocarbon resources potential mapping using geographic information system (GIS)

Client: National Iranian Oil Company

Date: 2014-2015

Project Director: Dr. Mohammad Karimi

Project associate members: Dr. Abbas Alimohammadi and Mohammad Arab Amiri

Project type: Design and Implementation

Project collaborator: K.N. Toosi University of Technology (KNTU)

Summary of project:

The main objective of this project is to design and implement a GIS-based model to determine the high potential areas for hydrocarbon reserves for further exploration work, including seismic surveys and exploration drilling. In this project, a data-driven approach, evidential belief function, were used to implement the model. A case study in Ahvaz/Khuzestan province, south-west of Iran, is proposed to assess the feasibility of this modeling

technique. Factors associated with hydrocarbon resources were assembled in a spatial database and a hydrocarbon resource potential map was created using the evidential belief function model. The method quantifies the spatial relationship between input data and the petroleum resources. This allows the exploration manager to identify those data themes that are the best predictors of petroleum prospects.

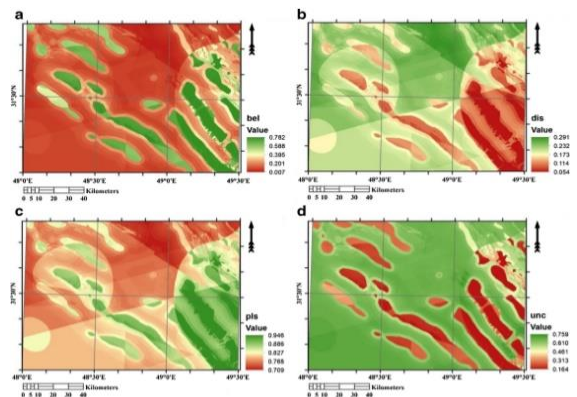
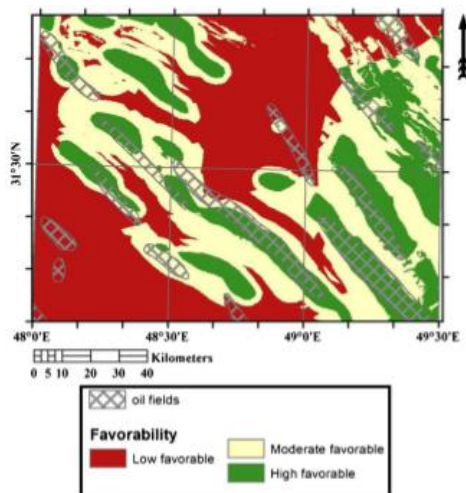

Development, design and implementation of an integrated performance monitoring and fault detection system for gas turbines

Client: National Iranian Gas Company

Date: 2008-2013

Project Director: Dr. Ali Khaki-Sedigh

Project type: Industrial Implementation

Project collaborator: K.N. Toosi University of Technology (KNTU) & Tourbotec Company

Summary of project:

Due to the strategic role of efficient and reliable energy production, the Iranian National Gas Company delineated and signed a contract with K N Toosi University of Technology to perform a research project on the development, design and implementation of an integrated performance monitoring and fault detection system for GT10B gas turbines

and Demag Delval compressors. The key objectives of the project include:

- Development of theoretical knowledge of an integrated performance monitoring and fault detection system for gas turbines.
- Software and hardware development and online implementation of the designed integrated system in GT10B gas turbines in Qom power plant.

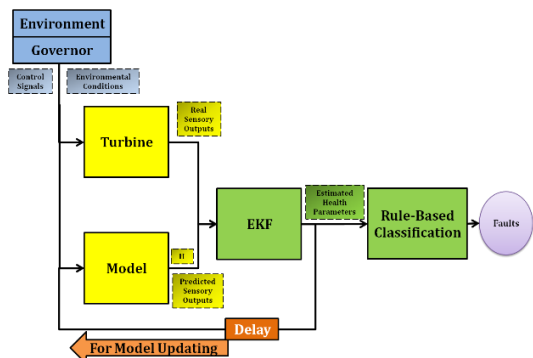
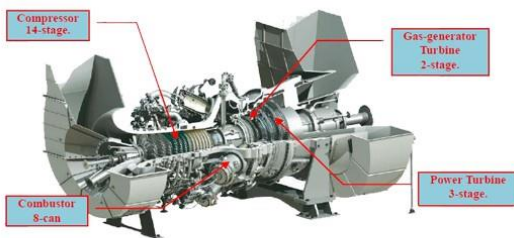

Design and implementation of Universal Control System (UCS)

Client: High-Tech Bureau of the Ministry of Industry

Date: 2005-2008

Project Director: Dr. Ali Khaki-Sedigh

Project associate members: Dr. Alireza Fatehi

Project type: Design, Development and Pilot Plant Implementation

Project collaborator: K.N. Toosi University of Technology (KNTU)

Summary of project:

Nowadays, Advanced Process Control (APC) systems are widely used in industry. However, the main challenge on the application of APC systems is tuning of their parameters, including model structure like model order, delay and model parameters, controller structure and parameters like control and prediction horizon in model predictive controllers, noise filters and so on. Practically, an APC expert should decide on them through some experimental test on the site. Every re-tuning of the controller also needs the presence of experts. This increases the commissioning and operational costs of APC, one of the main reasons that many industries avoid

using APC systems. By UCS, we developed an APC that only needs some operational available information, like the tag number of MV and CV, acceptable setpoint and MV step changes and so on. This makes the APC design a kind of plug-and-play procedure that can be handled by in residence automation engineers at the plant site. Both PID and APC controllers are automatically designed through some carefully, yet universally, step by step experiments. UCS has already been tested on some process systems, including level, flow, temperature, pressure and pH neutralization pilot plants.

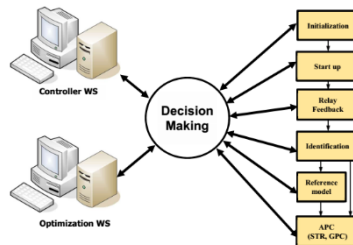
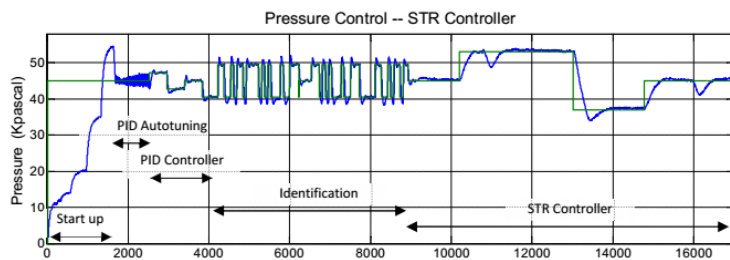

Degradation of textile dyes and 2, 6-dimethylphenol in the presence of manganese (III) porphyrin supported onto multi-walled carbon nanotubes

Client: K.N. Toosi University of Technology (KNTU)

Date: 2014-2016

Project Director: Dr. Saeed Rayati

Summary of project:

A manganese porphyrin supported onto multi-walled carbon nanotubes (Mn(TCPP)OAc@MWCNT) The heterogeneous catalyst was characterized by powder X-ray diffraction, FT-IR, atomic absorption and UV-vis spectroscopy, field emission scanning electron microscopy (FE-SEM) and also thermogravimetric analysis (TGA). The TGA curve shows that the nanocatalyst was thermally stable up to almost 350°C. This catalyst was found to be able to oxidize different synthetic textile dyes in aqueous media over a wide pH range at ambient temperature

with *tert*-butyl hydroperoxide (TBHP) as the oxidant. The influence of some important parameters such as initial pH of the dye solution, temperature, and concentration of the catalyst, oxidant, and co-catalyst was inspected. Also, the ability of this heterogeneous catalyst in the oxidation of 2,6-dimethylphenol (with excellent selectivity for quinone (86%)) with TBHP in acetonitrile was evaluated. The separation and recycling of the catalyst are simple and catalyst can be used several successive cycles without a significant decrease in catalytic activity.

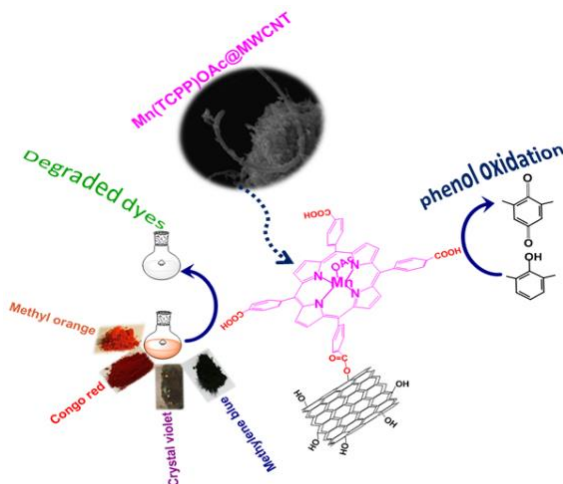

Aerobic oxidations of sulfides and alkenes over Fe-porphyrin supported onto multiwall carbon nanotubes as a model of P450 enzyme

Client: K.N. Toosi University of Technology (KNTU)

Date: 2014-2017

Project Director: Dr. Saeed Rayati

Project type: Laboratory experiment

Summary of project:

Aerobic oxidation of various olefins and sulfides were reported in the presence of Fe-porphyrin supported onto functionalized multi-wall carbon nanotubes. High yield of

products, excellent selectivity, short reaction time, mild conditions, and excellent reusability of the catalyst are of advantages of this catalytic system.

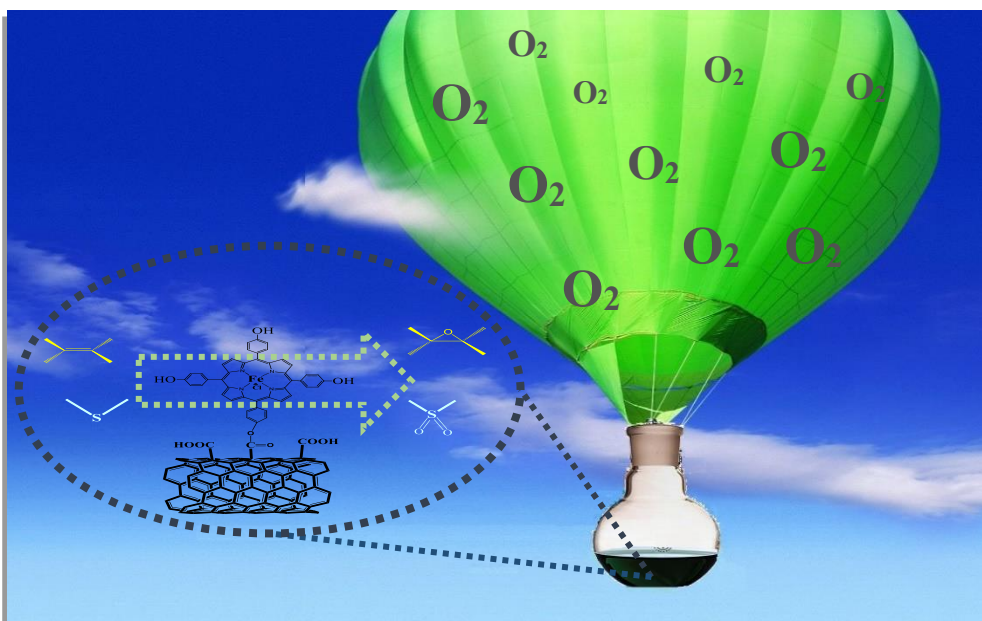

Data Reconciliation and Gross Error Detection of a Refinery Process

Client: Research Institute of Petroleum Industry

Date: 2009-2010

Project Director: Dr. Babak Tavassoli

Project type: Simulation study

Project collaborator: K.N. Toosi University of Technology (KNTU)

Summary of project:

This project was a part of a larger collaborative research on real-time optimization (RTO) of a Hydrodesulphurization (HDS) plant. An RTO system optimized the plant performance by adjusting the setpoints of the closed loop controller in real-time, i.e. during the operation of the plant. For this purpose, it is required to provide high-quality data for the online model-

based optimization. A way of improving the measurement quality is a correction of the measurement errors based on the available physical model of the plant. This process is known as model-based data reconciliation. Additionally, the plant model can be used to detect gross errors (large errors due to measurement failures).

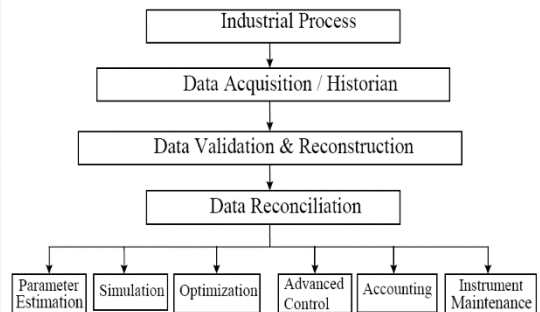
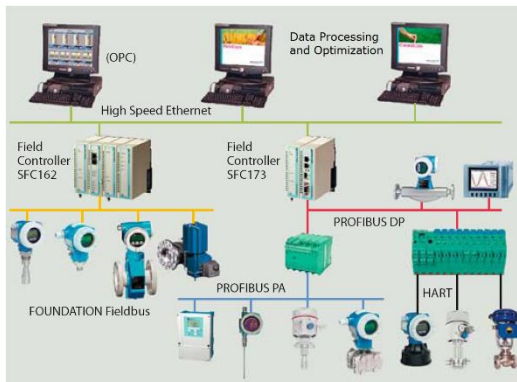

Control of Process Trajectory for avoiding failures and operational constraints

Client: Research Institute of Petroleum Industry

Date: 2009-2010

Project Director: Dr. Babak Tavassoli

Project type: Simulation study

Project collaborator: K.N. Toosi University of Technology (KNTU)

Summary of project:

This project was a part of a larger collaborative research on real-time optimization (RTO) of a Hydrodesulphurization (HDS) plant which is normally cascaded with the control system. An RTO system optimizes the plant performance by adjusting the setpoints of the closed loop controller in

real-time, i.e. during the operation of the plant. To achieve the benefits of the RTO system it is required that the control system provides an acceptable performance to eliminate oscillations and transient errors as much as possible. In this project, the model predictive control algorithm was utilized for this purpose.

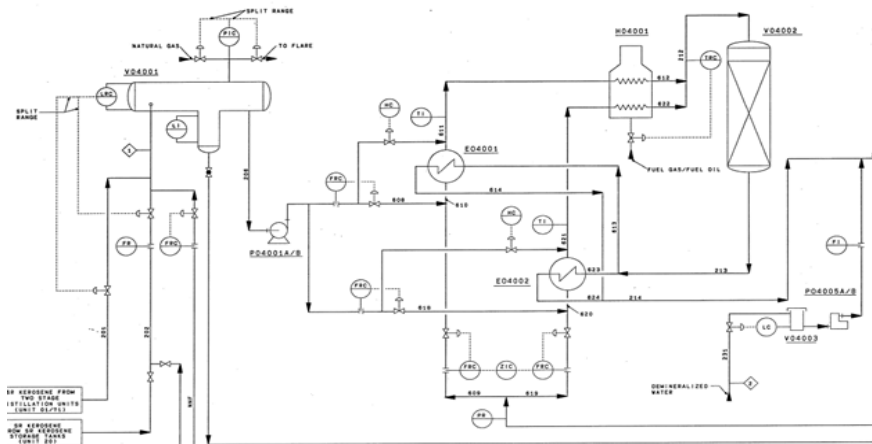

Integrating GIS and other practical software in Iranian Gas Transportation Company: Basic study

Client: Iranian Gas Transmission Company

Date: 2010-2011

Project Director: Dr. Mohammad Taleai

Project associate members: Dr. Mohammad Karimi, Dr. Mohammad Javad Valadan Zoej, and Dr. Hamid Ebadi

Project type: Feasibility study and design

Project collaborator: K.N. Toosi University of Technology (KNTU)

Summary of project:

The Iranian Gas Transmission Company (IGTC) signed a contract with K N Toosi University of Technology to perform a research project on the integrating geographic information system (GIS) and other practical software in Iranian Gas Transportation Company. In this project, a comprehensive description of current systems and databases in IGTC which

were related to GIS and spatial database were analyzed and summarized. The major outputs of this projects are includes:

- Definition of the mission, vision, and objectives of IGTC GIS
- Design of the architect of IGTC GIS
- Design of the architect of the integrating GIS, PIMS and CMMS systems in IGTC

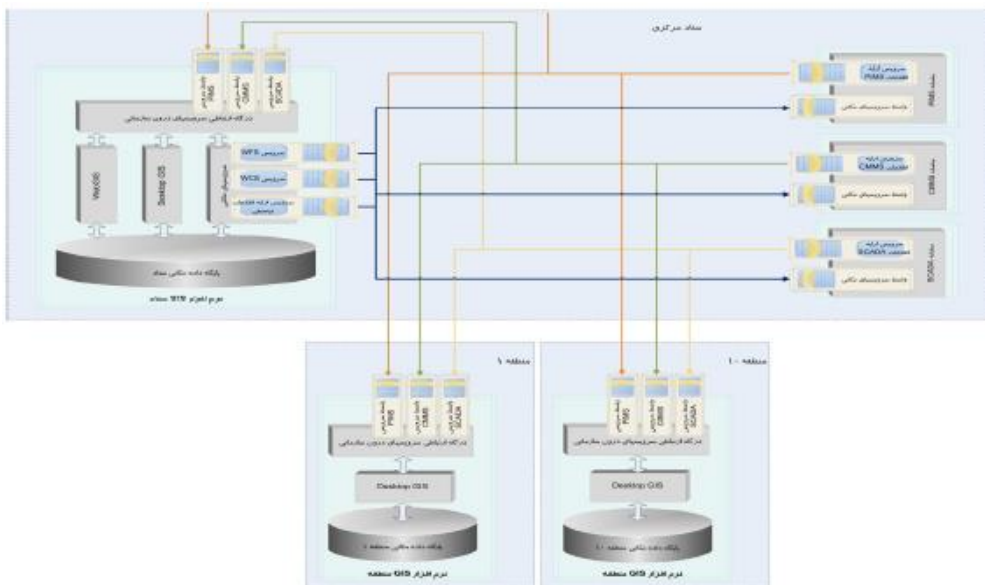

Risk Assessment of Transmission Gas Pipeline with Use of Spatial Analysis

Client: Iranian Gas Transmission Company

Date: 2015-2016

Project Director: Dr. Mohammad Karimi

Project type: Design and Implementation

Project collaborator: K.N. Toosi University of Technology (KNTU)

Summary of project:

The purpose of this study is to compute the risk of transmission gas pipeline, so GIS is used as a decision-making tool for the analysis of the pipeline and its surrounding environment and overlapping of factors and using of GIS analysis is provided. In this project, both indexing system and probabilistic risk assessment were implemented on sweet and sour gas pipeline with a length of 40 km in Bushehr Province. In indexing system

method, the lowest rating of the relative risk related to sour gas pipeline whit the range of 3-11. In a probabilistic method, the highest amount of risk is associated with the sour gas pipeline in the range of 0 to $1E-04 < IR < 2E-04$. Thus, creating a general framework of risk assessment in GIS platform is very functional to improve communication and cooperation between authorities, planners, and experts, in order to prevent and reduce damage accidents.

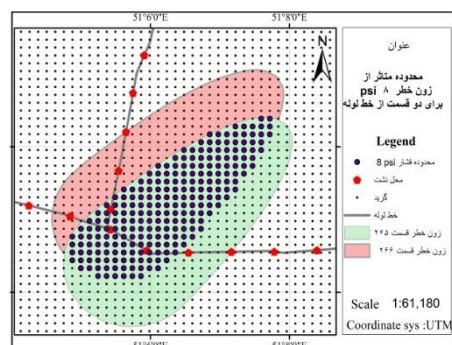
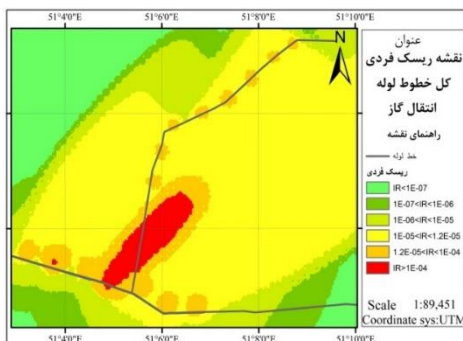

Gas Desulfurization for 1000 MWth Shahid Rajaei Powerplant

Client: Shahid Rajaei utility company, Iran

Date: 2015-2017

Project Director: Dr. Sadegh Seddighi

Project associate members: Dr. Sadegh Seddighi

Project type: Engineering, Pilot Plant Building

Project collaborator: K.N. Toosi University of Technology (KNTU)

Summary of project:

This project successfully designed and carried out the optimum desulfurization method for the Shahid Rajaei power plant. Sulfur emissions are proved to be among the most hazardous emissions from the fossil fuel leading to various human diseases and respiratory illnesses and acid rains. Shahid Rajaei power plant ordered this project in order to reduce its

sulfur emission using new engineering methods. Various desulfurization methods were designed for the client and finally, the economically optimum method is selected for the pilot unit capable of reducing the power plant sulfur emission to the new environmental protection agency standards.

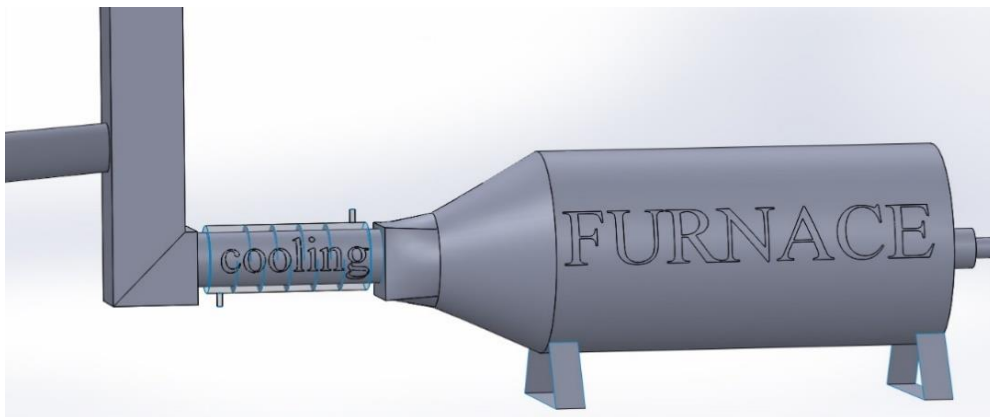

Model Predictive Control of a Gas Refinery Boiler

Client: Bidboland Gas Refinery

Date: 2012-2013

Project Director: Dr. Babak Tavassoli

Project type: Simulation study

Project collaborator: K.N. Toosi University of Technology (KNTU)

Summary of project:

In the gas refinement process, the required steam refinement unit is supplied by a boiler. A boiler system is a nonlinear and multivariable system involving several interacting control loops. In this process, the PID controller is normally used to control the pressure and liquid level of the vessel. However, it is not easy to achieve an acceptable performance with PID loops and avoid fluctuations. An improved control algorithm for replacing the PID controllers is the model predictive control algorithm. This algorithm has a

high computational load which can be reduced by applying the multi-parametric MPC control. Based on this, the boiler controller in the gas refinement unit is studied and a nonlinear model of the boiler has been obtained and validated using the data obtained from experiments at steady state. Then, the multi-parameter explicit predictive controller has been used to control the level and the pressure of the boiler. It is shown that the controller performance improves considerably.

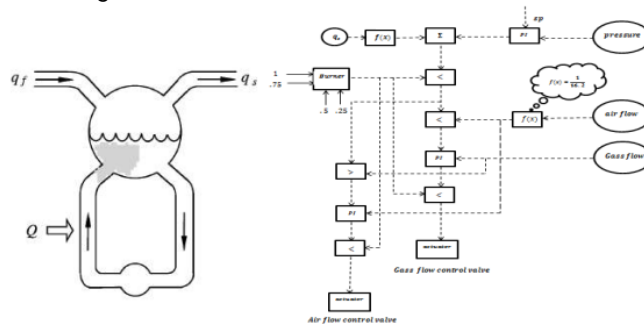

Advanced process control (APC) system for pH neutralization plant based on multiple model controller

Client: National Iranian Oil Refinery & Distribution Company (NIORDC)

Date: 2010-2011

Project Director: Dr. Alireza Fatehi

Project associate members: Dr. Ali Khaki-Sedigh

Project type: Design, Development and Pilot Plant Implementation

Project collaborator: K.N. Toosi University of Technology (KNTU)

Summary of project:

Without a proper control system, the production in any process plants, including refinery plants, cannot reach to technically high quality and economically compatible level. Therefore, any refinery plant needs an advanced process control (APC) beside its advanced automation system. However, conventional APC may be so complex that they cannot be practically operable in every process plants. In this project, a new configuration of APC is proposed for

refinery plants. The controller is based on multiple model controller, in which simple linear controllers are designed for some operating points of the process. A careful, but transparent, supervisory algorithm selects each controller at any operating point. This reduces the complexity of the control system, while keeps the overall quality in high level. The controller has been experimentally tested on a pH neutralization pilot plant.

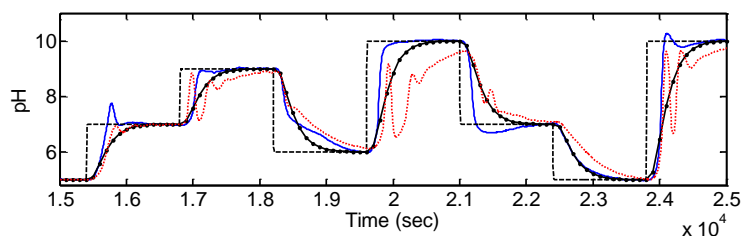
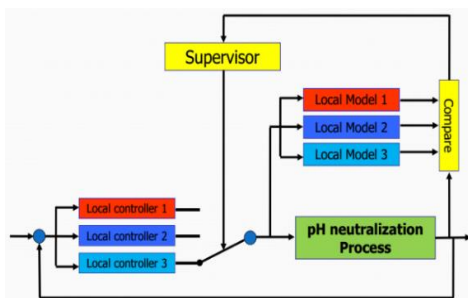

Experimental result on pH neutralization plant
 Black: desired pH, Blue: Proposed Multiple APC, Red: Conventional adaptive APC

Design and Construction of a Tele-operated (Melon) and an autonomous (Silver) robots

Client: National Iranian Oil Company (NIOC)

Date: 2006-2010

Project Director: Dr. Alireza Fatehi

Project associate members: Dr. Hamid Taghirad, Dr. Ali Mousavian

Project type: Design, Development and Robot Construction

Project collaborator: K.N. Toosi University of Technology (KNTU)

Summary of project:

Oil fields exploration and pipeline investigation are among top priority tasks in the oil industry. However, due to a vast area of exploration and hazardous nature of the oil fields, it is a difficult and dangerous duty. Nowadays, exploring robots become popular on investigating the hazardous plain area. To develop the technology of mobile robots with the capability of maneuvering in the oilfields

and across the pipelines, two robots have developed in this project. The melon robot is designed to explore plain areas using autonomous technology without human interference, while Silver robot, by using teleoperation technology, has the ability to explore not only plain areas but also can climb hills and stairs and pass some obstacles like woods and small rocks.



Silver Teleoperated Robot

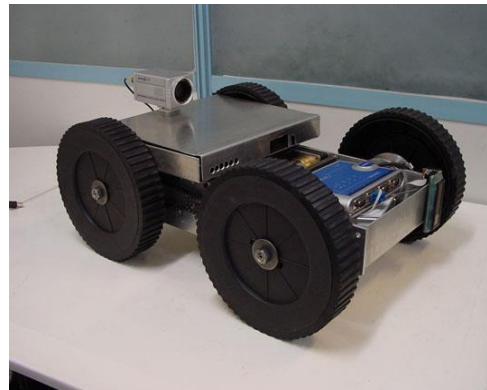

Melon Autonomous Robot

Feasibility study of advanced process control (APC) system in refinery plants

Client: National Iranian Oil Refinery & Distribution Company (NIORDC)

Date: 2009-2010

Project Director: Dr. Ali Khaki-Sedigh

Project associate members: Dr. Alireza Fatehi

Project type: Feasibility study

Project collaborator: K.N. Toosi University of Technology (KNTU)

Summary of project:

Advanced Process Control (APC) becomes the main part of any modern refinery plants of major oil production companies like BP, Shell, Chevron and so on. APC, like model predictive control (MPC), is an advanced control algorithm to manipulate the actuators in order to reach reliable and sustainable production. APC is widely used by control and automation provider companies like Honeywell, Yokogawa, AspenTech and so on, to

control different units of the refineries worldwide, like in distillation column, Fluid Catalytic Cracking (FCC) units. In this project, latest production and application of APC technologies by major control and automation companies have been studied. All the companies on the vendor list of NIORDC were investigated for any APC production. In addition, the applicability of different control algorithms is studied in the APC products of refinery industry.

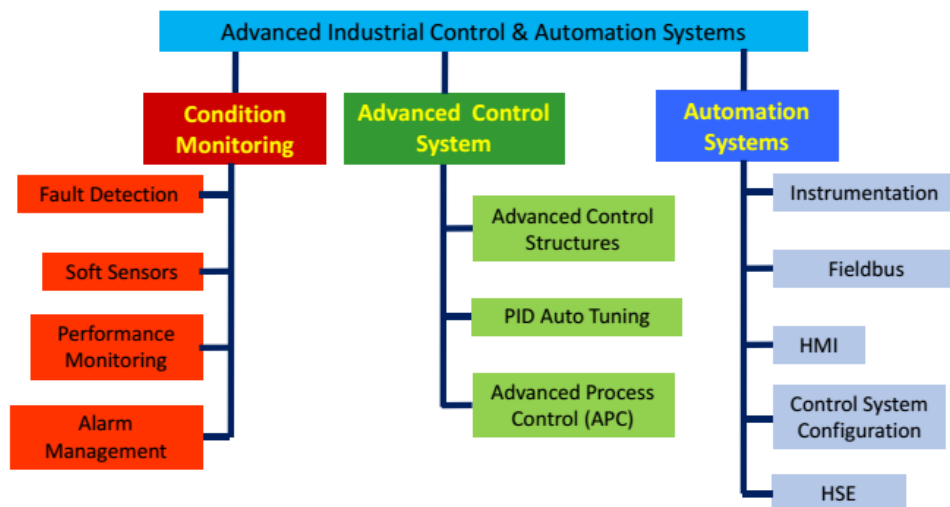

A comprehensive and sustainable program for production, supply and demand management of oil and natural gas products in Iran until 1404

Client: National Iranian Oil Products Distribution Company

Date: 2009

Project Director: Professor Majid Amidpour

Project type: Feasibility/Simulation study

Project collaborator: K.N. Toosi University of Technology (KNTU)

Summary of project:

In this project, the prospect of oil products in Iran, as well as the prospect of the National Company for Distribution of the Oil Products, are carefully investigated and analyzed in terms of market volume, required capacity building, environmental impacts of activities and development of company activities using the integrated model made in LEAP software. The report is designed as abstract. Due to the fact that most outputs are available in the model and also the model has been completed and approved in provincial dimension, so it's possible to benefit from the results in the model environment. In general, the report presented in this section can serve as a background and context for future development scientific planning and

position of company in the prospect. The developed model has the ability to accurately reflect the realities by calibrating and appropriate changing in each year, and, if used, can increase the accuracy of predictions by covering the likelihood of an unexpected event occurring in the future. The results are presented in three scenarios: high, middle, and bottom, which respectively indicate the reference scenario as a reflection scenario of the current technology trend and factors affecting the energy system, the scenario of implementing energy saving strategies, as well as the scenario for concurrent implementation of precious and non-precious tools for integrated management of energy system.

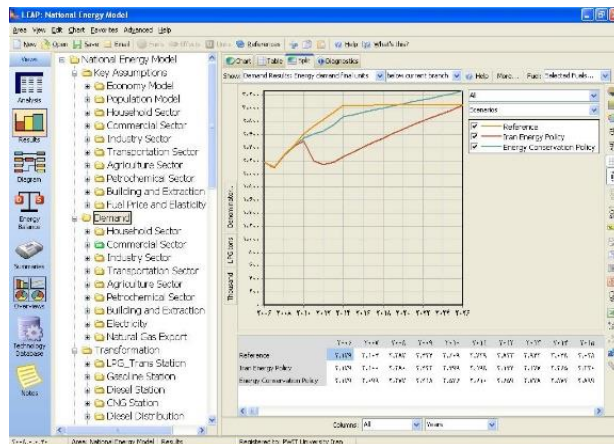

Compilation of fuel basket and fleet of light vehicles

Client: Iran Fuel Conservation Company

Date: 2010

Project Director: Professor Majid Amidpour

Project type: Feasibility/Simulation study

Project collaborator: K.N. Toosi University of Technology (KNTU)

Summary of project:

The fleet fuel basket and fuel of light vehicles has been prepared by the National Oil Products Distribution Company and in close cooperation with the Fuel Consumption Optimization Company. On the other hand, it should be said that a special model has been designed and implemented apart from the integrated model for the development of a lightweight vehicles fuel basket of the country. This means that the fuel basket model is only a very small part of the integrated energy supply and demand model and has a special application that has been modeled on the transportation sector of the country at the national level. Due to the sensitivity and importance of planning and policy making for the supply of fuel in the light transportation sector and the optimal supply of portfolio combinations in recent years, as well as the need for careful monitoring of some CNG fuel, the

National Oil Distribution Company applied changes in fuel basket and lightweight fleet due to the accelerated development of parameters such as regional fuel prices, infrastructure development costs and the addition of vans in cooperation with the company, which the modeling has been done by eliminating the model weaknesses and improving edition. It should be noted that the results were signed by the members of the previous LEAP team through the software at the end of spring, and the final approval of the respectable Minister of Oil has been reached as a national document. The model is based on the maximization of social benefits and also on the basis of the limitations and views of the leaders, experts, and high objectives of the Islamic Republic of Iran. In general, the document's formation space has been within the framework of the following main plans and policies.



- Diversification into fuel and technology in the transport sector of the country
- Implementation of lightweight vehicles fuel consumption standards
- Implementation of the law on targeting the energy subsidies of the country
- Implementation of the Law on Public Transport Development and Fuel Management
- Removing the Workshop Conversion of Gas Vehicles and Moving to Gas-Based vehicles
- Considering environmental costs in the supply and demand chain
- Sustainable fuel supply in the transport sector
- Gradual elimination of import tariffs and the maintenance of 1.2 million light-weight production capacity in the country
- Development of simple, plug and electrical hybrid vehicles in the coming years

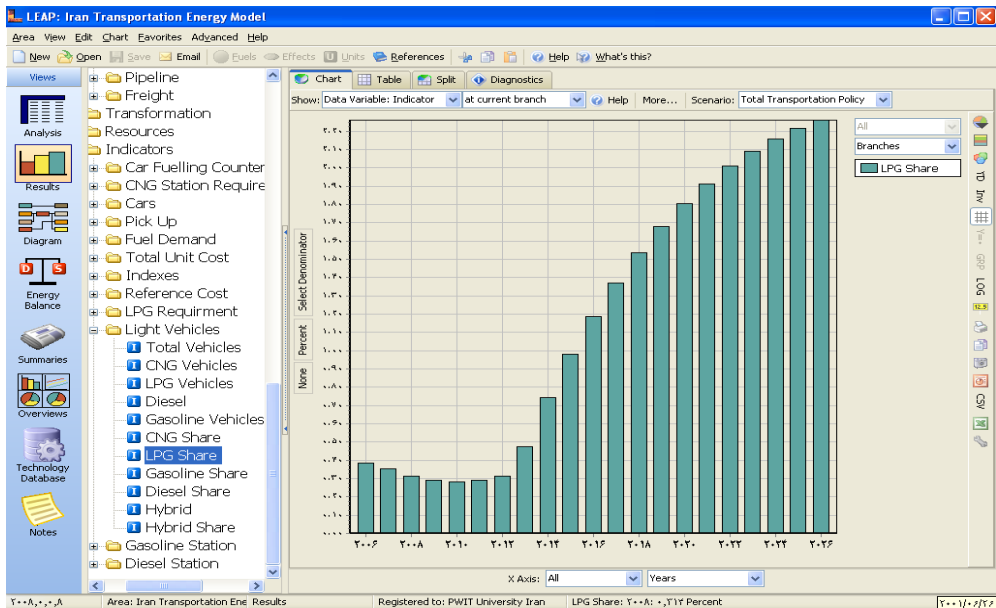

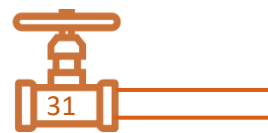

Analysis of the status of energy and electricity carriers, gas and oil products in selected villages of the Iran

Client: National Iranian Gas Company

Date: 2009

Project Director: Professor Majid Amidpour

Project type: Feasibility/Simulation study

Project collaborator: K.N. Toosi University of Technology (KNTU)

Summary of project:

In this study, after a quick look at the basic concepts of energy, the state of consumption of energy carriers in households and in particular the state of consumption of energy carriers in the villages of the country has been examined. After calculating the per capita of rural population, the electric equivalents of household consumptions were determined and then, by examining the current per capita consumption of electricity and current power of the Ministry of Energy, the priority has been selected to replace the oil products with electricity. Then, the effects of this practice have been evaluated from the viewpoint of the involved enterprises (ministry of energy, oil, households and producer factories). Finally, the only heating and cooking energy supply in the rural part of four provinces of Khuzestan, Sistan and Baluchestan, Bushehr and Hormozgan, due to the strong transmission and distribution capacity against strong loads, as well as the low heating rate of these provinces compared with other

provinces, were identified as the villages of selected provinces. On the other hand, in order to prioritize gas supplies to villages in different climates (separate from the provinces), a more basic and logical framework based on economic calculations and considering the opportunity cost and actual prices was used. Extraction of indices such as domestic and actual price of consumption basket of petroleum products for households by segregating the villages of the provinces, the ratio of the intensity of rural to urban gas consumption, and the rate of intensity change of the consumption of natural gas into the products after the replacement, strengthened the methodology framework and also enhanced the accuracy of outputs. Finally, from a national perspective, villages in each province, based on households and distances from natural gas sources, were prioritized and a specific and applicable framework was provided in each province.



Fundamental studies of Oxy-fuel Boilers-Phase I, funded by Metso, Sweden & Finland

Client: Metso Power Oy, Finland

Date: 2009-2011

Project Director: Dr. Sadegh Seddighi

Project type: Engineering, Laboratory/Pilot Plant Implementation

Project collaborator: Fortum Company (Sweden), Chalmers University

Summary of project:

This project which was funded by Scandinavian energy companies of Metso Power and Fortum, aimed at developing and encoding tools for the design and scale-up of oxy-fuel boilers across a wide range of operational conditions. The work

comprises fluid dynamics, combustion, and heat transfer and uses expressions that are proposed in this project or derived from the literature, together with experimental data obtained under both oxy-fuel-fired and air-fired conditions.

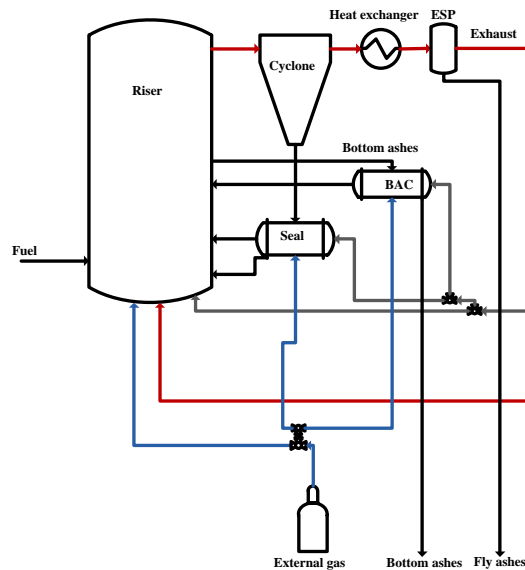
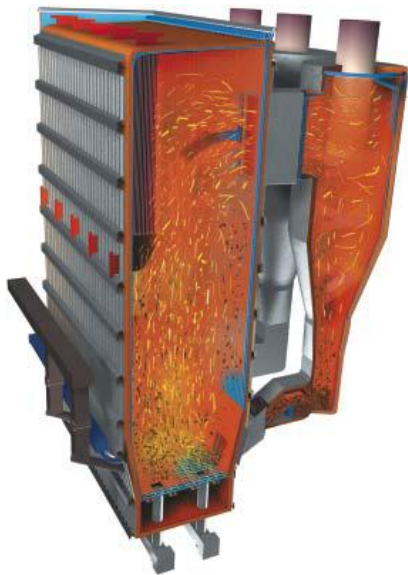

Design of large-scale Oxy-fuel Boilers-Phase II, funded by Valmet, Finland

Client: Valmet, Finland

Date: 2011-2014

Project Director: Dr. Sadegh Seddighi

Project type: Engineering, Laboratory/Pilot Plant Implementation

Project collaborator: Fortum Company (Sweden), Chalmers University

Summary of project:

This project carried out model simulations and validations for a broad range of operational conditions, involving both oxy-fuel firing and air-firing. The results were in good agreement with the data obtained in

this project using laboratory-scale (100-kW) and 4-MW industrial-scale, oxy-fuel-fired units. The designed model is used subsequently to design of a utility-scale (300–1100 MW) oxy-fuel-fired CFB boiler for the client.

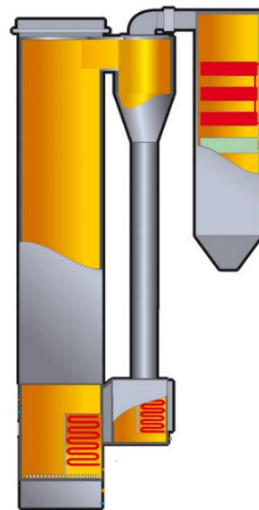
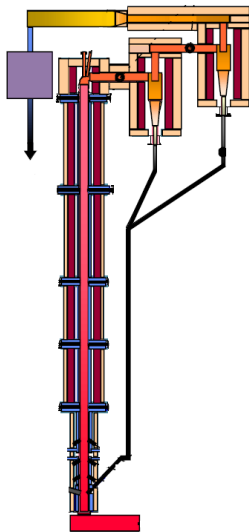

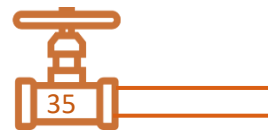

Developing an Appropriate Model and Practical Application of the Model for Estimating Natural Gas Demand in Khuzestan Province in a 20 Year-Old Horizon

Client: K.N. Toosi University of Technology (KNTU)

Date: 2009

Project Director: Professor Majid Amidpour

Project type: Feasibility/Simulation study

Summary of project:

In this research project, the detailed and regional demand for natural gas in Khuzestan province, according to each city, was simulated and estimated using energy system programming language, Leap. All sectors of the natural gas industry including domestic, commercial, industry, agriculture, transportation, petrochemicals, pumping stations and energy transmission stations, injection into oil reservoirs and oil and gas extraction, oil and gas refineries and electricity generation were accurately modelled and analyzed. Results including the annual demand process for natural gas, hour peak of gas demand and the number of potential customers in the 20-year horizons were calculated and extracted in the consumable parts of each city (cities in separated from and villages in a cumulative manner). The results of the project indicate that the total annual demand for natural gas in Khuzestan province will reach 56.6

billion cubic meters per year with considering the injection and 46.4 billion cubic meters without taking into account the injection in the perspective of 2025, due to the establishment of diverse, large and energy-intensive industries in the province. The daily peak of natural gas demand, with an injection of 226 million cubic meters per day, will amount to 198 million cubic meters per day, without injection. The province's gas demand forecast software was also prepared and presented with results. This software is flexible, which by training it to the respected experts, the company was able to make unpredictable changes and update it in the coming years. Examining the validity of the results of the project indicates its convergence with the total demand for natural gas in the country, and also in coordination with the opinions of the respected experts of the province gas.



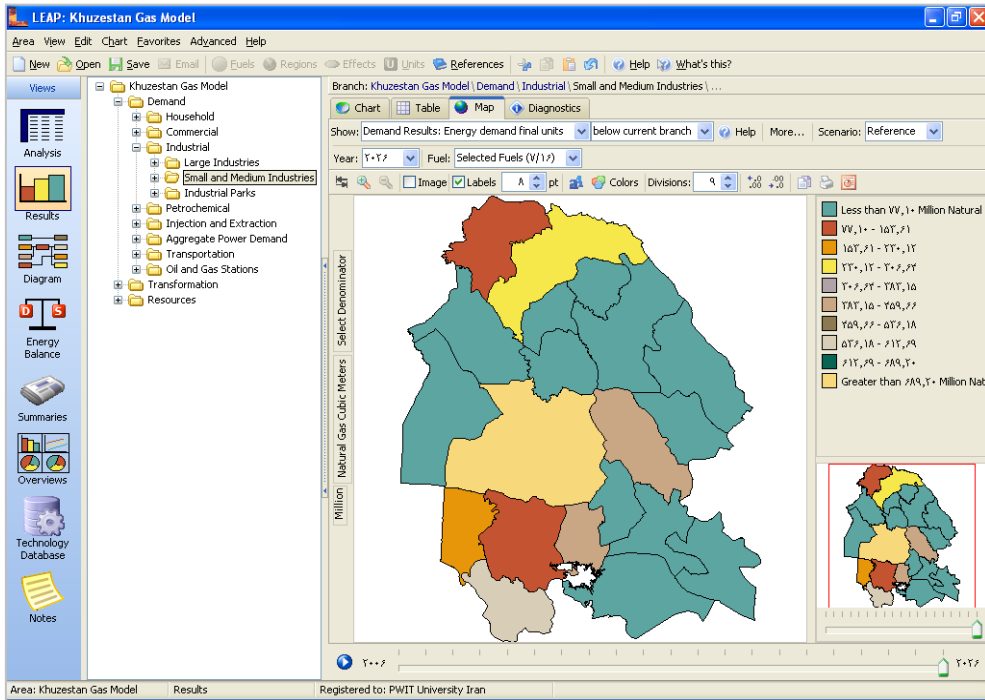

Commissioning of two automated phased-array ultrasonic testing systems

Client: National Iranian Gas Company – Iranian Gas Transmission Co.

Date: 2013-2015

Project Director: Prof. Farhang Honarvar

Project type: Commissioning

Project collaborator: K. N. Toosi University of Technology (KNTU)

Summary of project:

Iranian Gas Transmission Company (IGTC) purchased two units of automated phased-array ultrasonic testing systems, PipeWIZARD Ver. 2, from RD Tech (Canadian Company) in 2002. The PipeWIZARD is an automated girth weld inspection system which is suitable for in-site weld inspection in extreme environments. It uses conventional UT and phased array techniques. Due to the international sanctions against Iran, IGTC was not

able to get after-sales services (e.g., installation and commissioning) for these two units. Therefore, IGTC decided to invite domestic NDT experts from the KNTU to provide support for the initial set-up and installation of the PipeWIZARD systems at IGTC's premises. Commissioning stage of the units was successfully completed by measuring and interpreting the results obtained from a number of NDT reference standards.



Design and development of a long-range ultrasonic testing (LRUT) system as well as the optimization of hydrostatic testing for the inspection of gas transmission pipelines

Client: National Iranian Gas Company-Bushehr Province Gas Company

Plant Location: Bushehr - Iran

Date: 2014- Ongoing

Project Director: Prof. Farhang Honarvar

Project associate members: Dr. Soheil Nakhodchi

Project type: Laboratory/Pilot Plant Implementation

Project collaborator: K. N. Toosi University of Technology (KNTU) and Parsian Advanced Ultrasonic Testing

Summary of project:

Recent studies show that the Hydrotesting as the most common method employed for the pipeline integrity may cause damages to the structure, however, it might also improve some mechanical properties of the pipelines. Due to the growing use of hydrotesting of the pipelines in oil and gas industries, the first part of the project was therefore devoted to studying standards and procedures of this technique in order to provide all technical requirements and

optimized instructions. Furthermore, at the second part of the project, a new emerging technique so-called Long Range Ultrasonic Testing (LRUT) was designed, developed and implemented in order to replace the traditional Hydrostatic testing. This reliable and cost-effective technique takes advantage of guided waves to inspect and screen pipelines for damages at the long distances in a pulse-echo configuration mode.

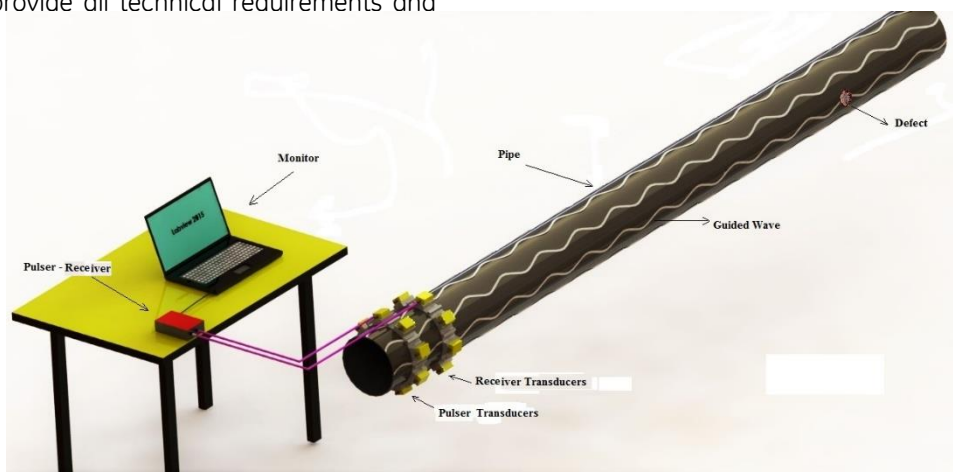

A Hydro-Thermo-Mechanical Model for Black Oil Reservoirs

Client: K. N. Toosi University of Technology

Date: 2008-2013

Project Director: Dr Hasan Ghasemzadeh

Project associate members: Dr. Sadrnejad, Dr. Ghoreishian

Project type: Engineering, Modeling

Summary of project:

A fully coupled thermo-hydro-mechanical model for simulating the black-oil type flow in stress sensitive reservoirs was presented. Thermal oil recovery processes involve high pressures and temperatures, leading to large volume changes and induced stresses. To identify these deformation and stresses, we developed a thermal reservoir simulator. The accuracy and efficiency

of the model was verified by simulating some experiments and benchmark problems. The key objectives of the project include:

- Development of theoretical knowledge of integrated equations of heat and black-oil flow in deformable reservoir.
- Software development for numerical solution of multiphase flow in deformable porous media.

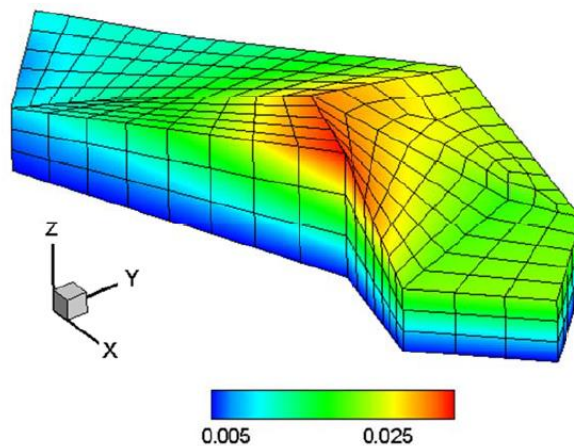

Multiscale Modeling of Oil Transport in Deformable Porous Media

Client: K. N. Toosi University of Technology

Date: 2009-2015

Project Director: Dr Hasan Ghasemzadeh

Project type: Engineering, Modeling

Project collaborator: Dr. Sadrnejad, Dr. Taheri

Summary of project:

Reservoir formations typically display high degrees of spatial variations over multiple length scales. Moreover, several physical phenomena affect the flow pattern in different hierarchies. However, a full description of flow and deformation that includes all these scales exceeds the current computational capabilities. To overcome this deficiency, each physical effect should be treated separately on its area of influence. In this project the finite element method is combined with Multiscale Finite Volume (MSFV) to solve the solid equilibrium and fluid flow equations. The accuracy and efficiency

of the code was verified by simulating some experiments and benchmark problems which the results show the high computation efficiency of developed code. The key objectives of the project include:

- Development of theoretical knowledge of governing equations of multiphase flow in deformable reservoir.
- Software development for numerical solution of the Multiscale/Multiphysics Mixed Geomechanical Model.

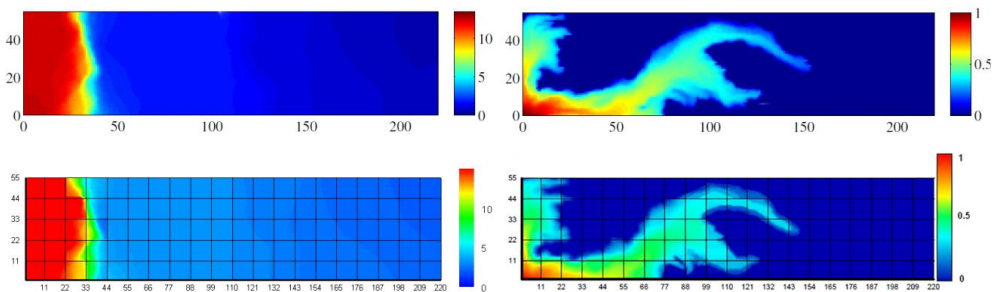

Oil Flow Modeling In Naturally Fractured Reservoirs by a Fully Coupled Thermo-Hydro-Mechanical Approach

Client: K. N. Toosi University of Technology

Date: 2015

Project Director: Dr Hasan Ghasemzadeh

Project type: Engineering, Modeling

Project collaborator: Mrs Harif Bilandi

Summary of project:

More than 60 percent of oil reservoirs worldwide, quite all of the thermal energy reservoirs and most of the Iranian oil reservoirs are placed in fractured formations. These fractures are of great influence in the medium properties and extraction behavior. The project focuses on code developing in Geomechanics and multi-

phase flow in naturally fractured reservoirs by a fully coupled thermo-hydro-mechanical approach. This program solves the equations governing in a dual-porosity medium consisting of matrix and fractures with multiphase flow in a geometrically complex medium in a fully coupled approach.

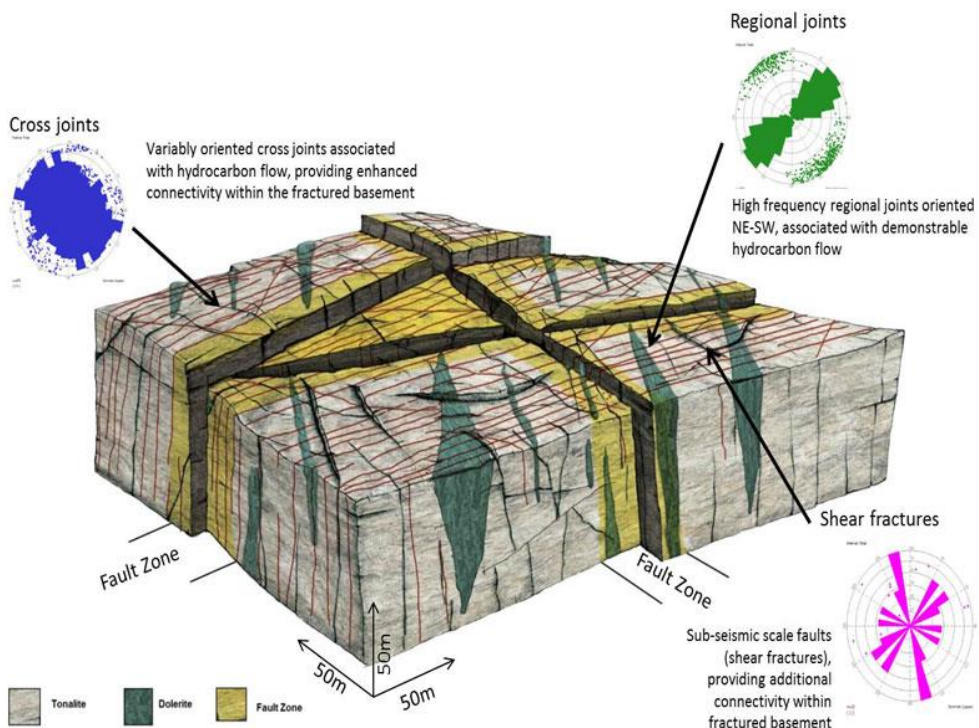

Pirani vacuum gauge with platinum filament

Client: Hezareh-Sevom Company

Date: 2014-2017

Project Director: Prof. Faramarz Hossein-Babaei

Project associate members: Ehsan Yousefiazari, Armin Alizadeh

Project type: Industrial implementation

Project Collaborator: K. N. Toosi University of Technology

Summary of project:

Pirani sensor is the most commonly utilized vacuum gauge. This device measures low atmospheric pressure by estimating thermal conductivity of the prevailing atmosphere. The nominal measurement range is 0.1-1000 Pa, which partly covers the vacuum range produced by rotary pumps. These gauges present fairly reproducible measurement results in clean atmosphere chambers, but

presence of atmospheric contaminations can irreversibly hinder their accuracy. The sensor head in Pirani gauge comprises a metallic filament, the electrical resistance variations of which is monitored with an appropriately designed bridge. Commonly, tungsten wires are utilized for this purpose; we have altered the design to allow using platinum filaments instead. The device is at the stage of industrial production.



The fabricated Pirani vacuum gauge

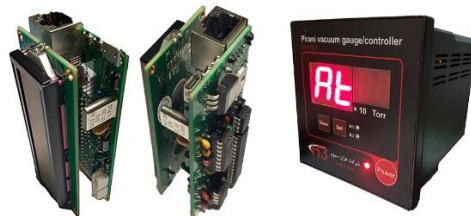

Pirani hardware developed in this project.

A gold/organic semiconductor diode for ppm-level humidity sensing

Client: K. N. Toosi University of Technology
 Date: 2011-2015
 Project Director: Prof. Faramarz Hossein-Babaei
 Project associate members: Dr. Pejman Shabani
 Project type: Laboratory implementation

Summary of project:

Measuring humidity in ppm level is of major technological importance, particularly in petrochemical plants where the activity of nanoporous catalysts determines the process progress rates, and also in low-loss optical fiber production units where hygrometry at extremely low humidity levels in air, vacuum, and inert gas backgrounds is a vital necessity. In this project, a novel electronic humidity sensor is fabricated by depositing gold nanolayers on an air-stable hydrophobic organic semiconductor, oxidized poly[2-methoxy-5-(2-

ethylhexyloxy)-p-phenylene vinylene] (MEH-PPV). The device demonstrates high sensitivity at H₂O concentrations as low as ~1 ppm in air, vacuum and inert backgrounds. The presence of gases such as CO₂ and H₂ in substantial concentrations and oxygen partial pressure variations in air do not interfere with the sensing process. The device is affordable and easy to fabricate in a wide range of sizes and shapes and is anticipated to find a variety of applications in different branches of science and technology.

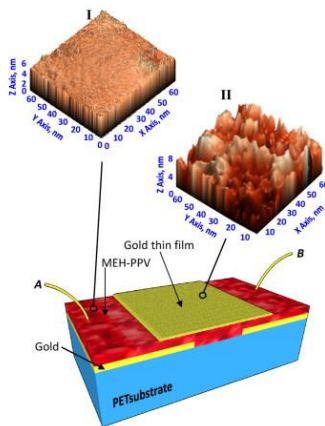

Structure of the fabricated humidity sensor.

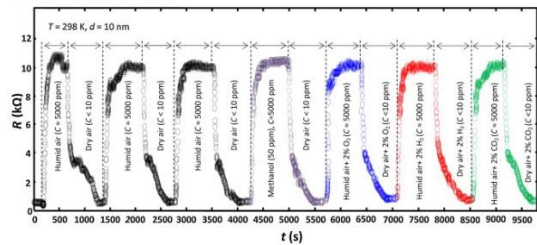

Humidity sensing at different background atmospheres.

PEDOT:PSS-coated microchannels: a selective filter for volatile organic compounds

Client: K. N. Toosi University of Technology

Date: 2015-2018

Project Director: Prof. Faramarz Hossein-Babaei

Project associate members: Dr. Ali Hooshyar Zare

Project type: Laboratory implementation

Summary of project:

In this project, a sharply selective filter for volatile organic compounds is designed and fabricated. The device is a microchannel with Poly(3, 4-ethylenedioxythiophene)-poly(styrenesulfonate) (PEDOT:PSS)-coated walls which can be used to separate ppm-level contaminations from background gases in a microfluidic circuit. This behavior stems from the physicochemical properties of the surface of the functional coating applied to the channel walls, which are amplified by the physics of the microfluidic channel; the filtering action disappears in large cross-section channels. The coated channel

transports hydrogen, carbon monoxide, hexane and benzene similar to the uncoated while effectively blocking both diffusion and drift of methanol and ethanol. Separation factor between n-hexane and ethanol is larger than 103. These microchannels coupled to appropriate sensors can be considered for numerous applications in selective chemical sensing and biomarker detection. At its present configuration, the introduced device can be utilized for detecting low levels of carbon monoxide or benzene in highly alcohol-contaminated background atmosphere.

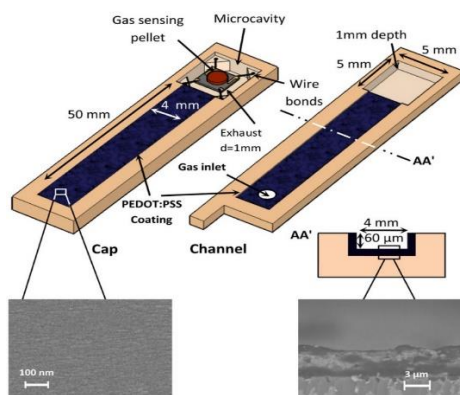

The fabricated PEDOT:PSS-coated microfluidic channel integrated with a gas sensor.

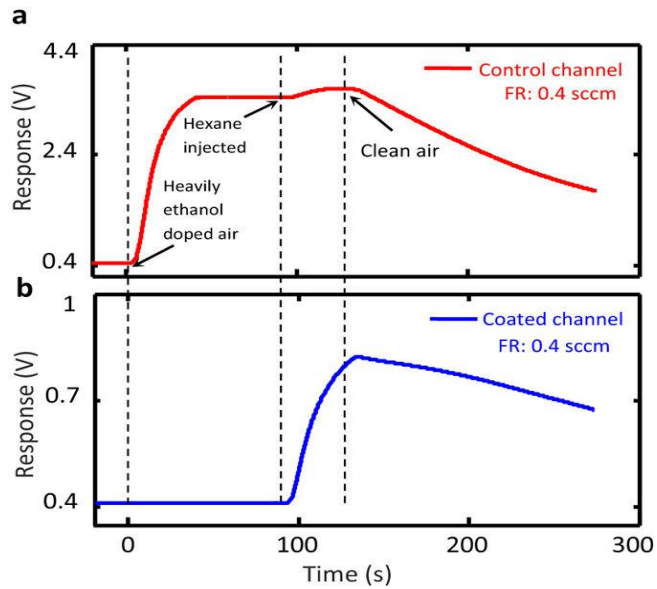

The selective flow of contaminants through the uncoated (a) and PEDOT:PSS-coated microchannels.



Tin oxide gas sensor on tin oxide microheater for methane sensing

Client: K. N. Toosi University of Technology

Date: 2015- Ongoing

Project Director: Prof. Faramarz Hossein-Babaei

Project associate members: Mohsen Gharesi, Maryam Moalaghi

Project type: Pilot plant implementation

Summary of project:

The explosive nature of methane and its role in global warming have made detecting its leakage important. Significant amounts of natural gas are lost along pipelines causing billion-dollar economic losses each year. The common chemiresistive methane sensors fail to satisfy the quality requirements for long-term operation in harsh environs. Particularly, the RuO₂ microheaters utilized in these sensors deteriorate in reducing atmospheres and cannot provide the high temperatures required for

methane detection in long term. In this project, a tin oxide gas sensor is fabricated on a tin oxide microheater which can stably operate at temperatures as high as 850 °C. Both components are produced by ultrasonic spray pyrolysis of tin chloride solutions on alternative sides of an alumina chip. Thermally stable electrical contacts are formed by diffusion bonding of gold wire segments. The device can detect 50 ppm of methane in normal atmosphere with a response time of 10 s.



Photograph and SEM micrographs of a tin oxide methane sensor.

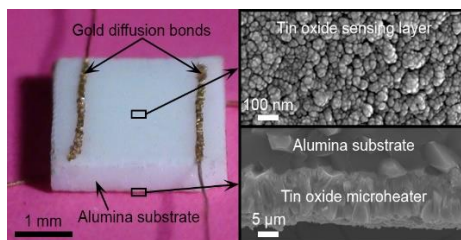

Photograph and SEM micrographs of a tin oxide methane sensor.

Single sensor electronic nose, trainable for different industrial applications

Client: K. N. Toosi University of Technology

Start Date: 2005-2017

Project Director: Prof. Faramarz Hossein-Babaei

Project associate members: Dr. Seyed Mohsen Hosseini-Golgoo, Dr. Amir Amini

Project type: Laboratory implementation

Summary of project:

Sensor array-based electronic noses suffer from multi-dimensional drift and require cumbersome calibrations frequently. In this project, a virtual array-based electronic nose is developed which can repeatedly operate over long term. The device utilizes only one chemiresistive gas sensor which is stimulated with thermal shocks of varying profiles and

magnitudes. The temporal responses of the sensor, recorded as voltage variations, are processed for obtaining information regarding the nature of the gaseous analyte. The system is used for the comparison and recognition of analyte classes after appropriate training. The device can discriminate among both simple and complex odors in only 4 s.

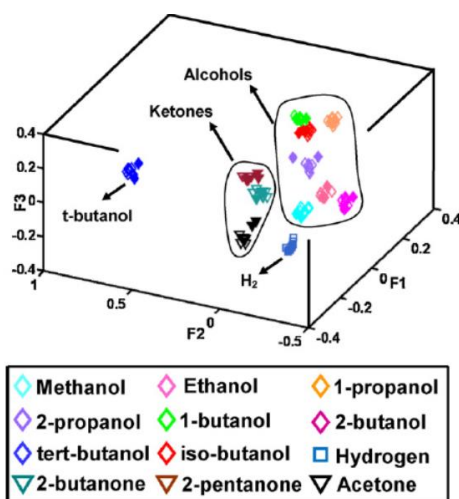

3-dimensional feature space showing successful discrimination among 12 simple odors.

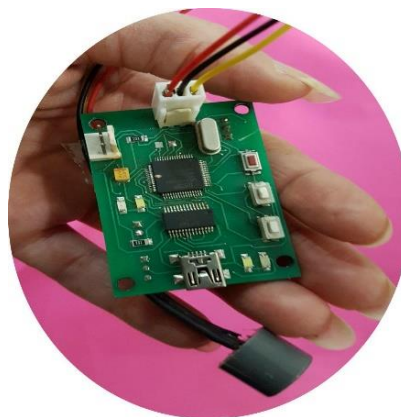

Photograph of the developed single-sensor electronic nose.

Microfluidic electronic tongue

Client: K. N. Toosi University of Technology

Date: 2009- Ongoing

Project Director: Prof. Faramarz Hossein-Babaei

Project associate members: Dr. Kianoosh Nemati, Asma Souri, Hasti Sardari

Project type: Laboratory implementation

Project Collaborator: K. N. Toosi University of Technology

Summary of project:

An electronic tongue is developed in which the discriminative information are obtained by monitoring the diffusion progress rates of ionic species in liquid-filled microfluidic channels. The fabricated prototype is made of two microfluidic channels and can classify simple and complex analytes and distinguish among sour and salty electrolytes.

Owing to its simplicity and inexpensiveness, the device can be disposablely utilized for fast recognition of liquid analytes. Electronic tongues are sought after for monitoring the contents and comparison of the liquids with complex ingredients in various branches of food, chemical, and petrochemical industries. Water quality monitoring is an example.

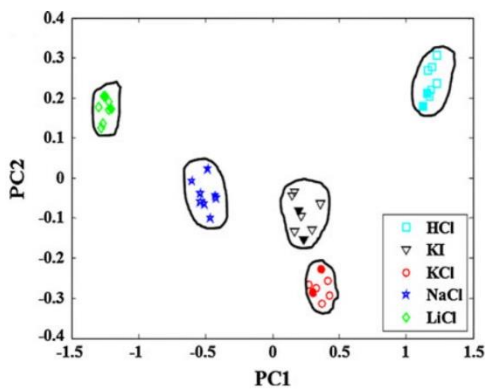

Feature space classification of analytes using the developed electronic tongue.

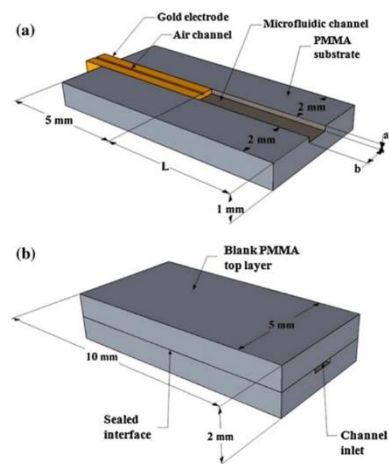

The fabricated microfluidic channel before (a) and after (b) placing the cap.

Feasibility study for Development of Thermoelectric Generators Package for Plant Waste Heat Energy Harvesting Systems

Client: National Iranian Oil Terminals Company at Kahrg Island

Date: 2016-2018

Project Director: Dr Masoud Asgari

Project type: Feasibility study and Pilot Plant Implementation

Project collaborator: K.N. Toosi University of Technology & National Iranian Oil Terminals Company

Summary of project:

The search for cleaner, more sustainable energy sources is an ever-growing global concern because of escalating costs and global warming associated with fossil fuel sources. Among the viable technologies for this purpose, thermoelectric energy converters are of increasing interest which is developing fast in recent years. Thermoelectric materials are able to generate electricity in the presence of temperature gradient. On the other hand lots of waste heat energy could be

found in oil and power plants industries. In this study we have designed and developed a thermoelectric generator system to harvest energy from plants waste heat. We have first of all developed a simulation based on data obtained via field measurements. A prototype has been constructed and installed on the power plant at Karg Island. Validation test and economical and technical calculation could be done based on the pilot implementation shows great potentials for development of this technology.

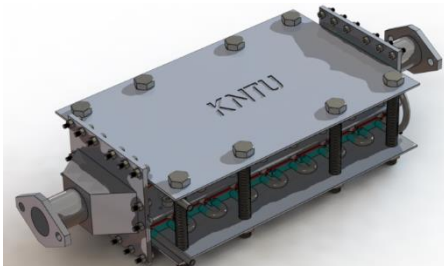

SnO₂:F conducting films for long-life transparent electronics

Client: Hezareh-Sevom Company

Date: 2016- Ongoing

Director project: Prof. Faramarz Hossein-Babaei

Project associate members: Mohsen Gharesi, Alireza Ranjkesh

Project type: Pilot plant implementation

Project Collaborator: K. N. Toosi University of Technology

Summary of project:

Transparent conductors (TCs) are in great demand in electronic industries; local production of TCs even at laboratory scale is still lacking. In this project, fluorine doped tin oxide (FTO) films are fabricated and characterized as TCs. The films are grown on soda lime and silica glass substrates by ultrasonic spray pyrolysis. The products exhibit sheet resistances in the order of $10 \Omega \cdot \text{sq}^{-1}$ and fine transparency in the visible spectrum. Thermal annealing of FTO films in air at temperatures as high as 500°C does not alter their electrical and optical

characteristics. Electrical contacts of ohmic quality are made by both silver paste printing and diffusion bonding. Owing to their high temperature stability and resistance to harsh environs, the fabricated devices can function as long-life transparent electrodes and defrosters in many electronic, optoelectronic, and electrochemical devices. The device is used for the manufacturing of windows with active defogging implement for storage units operating below room temperature at chemical and petrochemical industries.

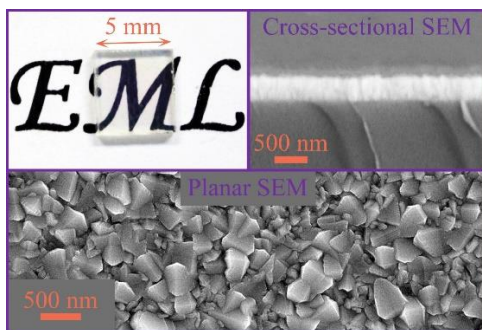

Photograph and SEM micrographs of FTO TCs deposited on soda-lime glass slides.



An FTO coated fused silica glass.

CFD validation of CO₂ adsorption model and experiments on Cu-BTC

Client: K. N. Toosi University of Technology

Date: 2018- On going

Project Director: Dr. Shima Najafi Nobar

Project type: Modeling

Summary of project:

Vacuum Swing Adsorption (VSA) is broadly used for industrial gas separation technologies based on the principles of adsorption. This process can be widely used in CO₂ capture and sequestration (CCS) which is very essential in flue gas cleanup. A four-step VSA process comprises pressurization, adsorption, forward

blowdown and reverse evacuation steps as can be seen in the figure below. In a VSA process, the steps constituting the cycle are repeated continuously in the same sequence. The cyclic operation on each bed continues and after a while the beds reach cyclic steady state when the recovery and purity of the products are no longer changed.

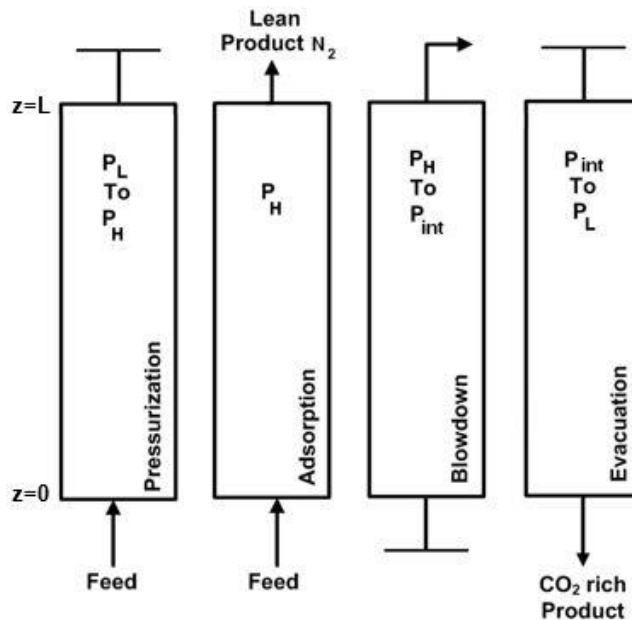

Schematic of four-step VSA process

Adsorption and Diffusion of Gases in Cu-BTC

Client: National University of Singapore (NUS)

Date: 2007-2013

Project Director: Prof. Samsuzzaman Farooq

Project associate members: Dr. Shima Najafi Nobar

Project type: Laboratory (Synthesis of material, design and implementation of setup), Modeling

Summary of project:

In this project, several samples of Cu-BTC, a member of the MOF adsorbent family, were synthesized following synthesis routes that represent some modifications of published recipes. The sample that gave stable adsorption capacity after several adsorption-desorption cycles was chosen for further study. The equilibrium and kinetic measurements of natural gas and biogas components, CO₂, CH₄ and N₂, were performed on this screened sample. Single component isotherm measurements of the aforementioned gases were conducted over a wide range of pressures and temperatures

using a constant volume apparatus, designed to minimize the required amount of adsorbent. The experimental adsorption equilibrium data of all three gases were well captured by the Langmuir isotherm model. The equilibrium data for the three gases were also compared with those on a commercial Cu-BTC sample, produced by BASF and marketed as Basolites C300. In addition, extensive dynamic column breakthrough experiments were conducted with the synthesized sample to establish the gas transport mechanism.

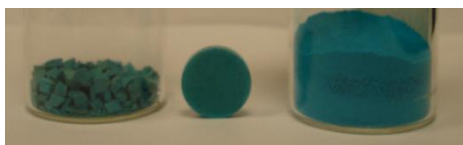

Cu-BTC synthesized sample (up), and constant volume apparatus for isotherm measurements



Adsorbent Selection for Hydrogen Storage

Client: K. N. Toosi University of Technology

Date: 2017

Project Director: Dr. Shima Najafi Nobar

Project type: Modeling

Summary of project:

A Comparison between adsorbents for hydrogen storage have been carried out and some types of MOFs and Carbon based materials have been investigated. Two

factors namely adsorption capacity and operation conditions have been evaluated and the best adsorbent was selected.

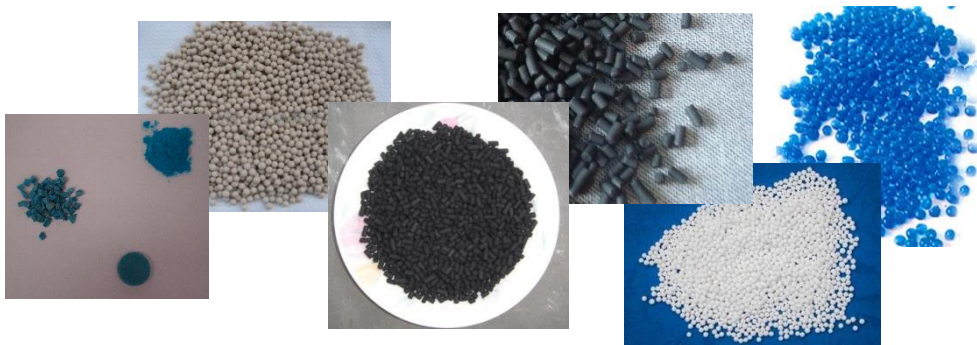
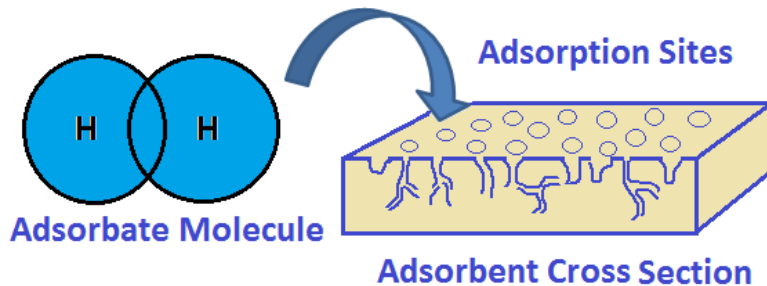

Schematic of hydrogen molecule adsorption on the surface of porous solid (top), different types of commercial and non-commercialized adsorbent materials.

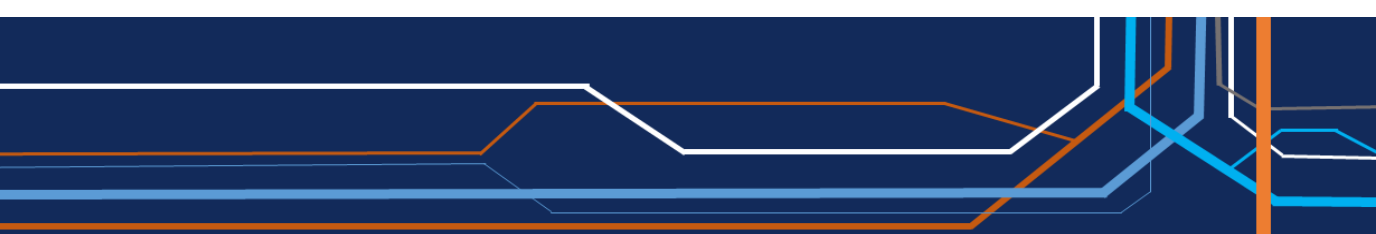



Feasibility Study of Managed Pressure Drilling (MPD) in Iran Oil Fields

Client: SEDCO / NDCO

Date: 2014-2015

Project Director: Dr. Yaghoub Jalili Khosroshahi

Project associate members: Dr. Shima Najafi Nobar

Project type: Feasibility Study

Summary of project:

The scope of the project:

- Analysis of the MPD system and its components
- Decision for using MPD system
- Selecting among the companies that provide this system

The project targets:

- Studying and understand the types of drilling methods under

pressure and to select the desired method

- Investigating and recognizing the companies providing these services and examining the possibility of technology transfer
- Review the company's current status regarding the feasibility of using this technology and determining the points of improvement

Adsorbent Selection for Methane Storage using in adsorbed natural gas vehicles (ANGV)

Client: K. N. Toosi University of Technology

Date: 2017- On going

Project Director: Dr. Shima Najafi Nobar

Project type: Modeling

Summary of project:

There are three main methods to store natural gas. LNG (Liquefied natural gas) and CNG (Compressed natural gas) are popular ones which became practical but there are some issues that lower their efficiency and causing some hazards. For example, CNG tanks work in relatively high pressure and limit the driving range to about 140-190 km. LNG system needs very low temperature and its costs are illogical. ANG (Adsorbed natural gas) led us to store methane at relatively low pressures (3.5 Mpa) and ambient temperature. Thus, it has been considered as a promising storage process for the vehicles. In this process, natural gas adsorbs on a porous adsorbent. If a proper adsorbent is used, it has the potential to store more gas in an adsorbent-filled vessel compared to

an empty vessel without adsorbent. Since ANG tank have lower pressure, it could be designed in flat shape to take less volume in a car. Moreover, energy density could be a good Indicator to show that ANG is more beneficial than other methods. This work, focuses on selecting the best adsorbent by comparing four parameters which are the volume of methane adsorbed per unit volume of adsorbent material, maximum saturated capacity, desorption behavior of the adsorbents and adsorbent surface area. For this purpose, some types of adsorbents are compared and the best one would be suggested. Carbon-based Materials and some MOFs are most promising candidates which the main focus of this work have been on these sorbents.

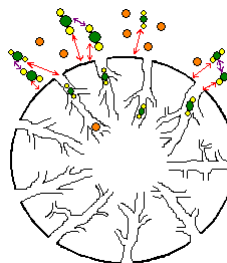
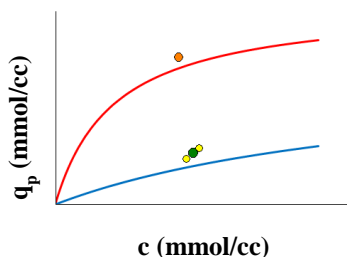

Schematic of equilibrium based adsorption (right), adsorption isotherms of two gas molecules (left).

Conceptual design of neutron gamma tool for determination of porosity and C/O ratio in the gas bearing formation

Client: K. N. Toosi University of Technology

Date: 2014-2016

Project Director: Dr Faezeh Rahmani

Project type: Simulation study

Summary of project:

It is necessary to extract petrophysical information from geophysical measurement to evaluate formation before drilling. Information about porosity and C/O ratio lead to determine the oil formation data. The neutron-gamma logging is one of the most widely used tool in the oil and gas industry for measuring porosity and the ratio of carbon to oxygen (C/O ratio). For this purpose, the conceptual design of this tool has been performed using Monte Carlo simulation. In order to measure porosity, the Hydrogen index (H-index) should be measured simultaneously which has been performed using gamma spectroscopy. So, the sonde including a

pulsed neutron generator (D-T) and two large LaBr₃(Ce) scintillator detectors (two near and far detectors with distance of 20 and 50 cm from neutron source and dimension of 5 and 7 inch, respectively) has been proposed. Gamma from non-reactive interaction with carbon and oxygen is measured for C/O ratio that used for recognizing between hydrocarbon and water content of formation. For gamma spectroscopy, 10Boron layer with 2 mm thickness has been used to cover detectors. With this design, porosity up to 40% with error better than 3% can be measured in sandstone, calcite and dolomite formations.

Sandstone calibration borehole test with 40% in porosity			
		C/O ratio	
Porosity: 100% water		1.61±0.02	
Porosity: 100% oil		1.86±0.02	
Test in sandstone borehole (Diameter=20 cm) with 18% in porosity			
Fluid	Borehole with case	Borehole without case	C/O
Water		*	1.49
Water	*		1.54
Air		*	1.67

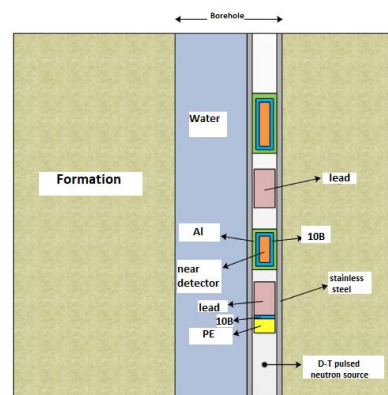

Conceptual design of gamma-gamma logging tool for determining gas bearing formation density

Client: K. N. Toosi University of Technology

Date: 2014-2016

Project Director: Dr Faezeh Rahmani

Project type: Simulation study

Summary of project:

In this project, the conceptual design of Gamma- Gamma Density Tool has been proposed which is one of the most widely used tool for recognizing underground layers such as petroleum or minerals. Different designs of existing gamma-gamma tools have been studied and after the full comparison of tools with similar application, the conceptual design has been introduced. The type of radioactive source (50 mCi, ^{137}Cs) and its position as well as the distance of detector/detectors (3 and 5 inch NaI(Tl) as near and far detector) from the source by considering the optimum radiation shielding has been determined using Monte Carlo simulation. Counting analysis (investigating the appropriate detector

response) has been performed based on the petroleum and mineral formations. Analysis of tool's behavior based on the various parameters (bed thickness, density and thickness of mud cake, optimum distances between two detectors) has been performed. Finally, the design of gamma-gamma tool using two detectors as well as its calibration curves has been presented for determining density in various formations with/without mud cake with different densities. In addition, capability of using this designed tool in gas bearing formation was investigated. Speed of tool with vertical resolution of 20 cm is 40 cm/s.

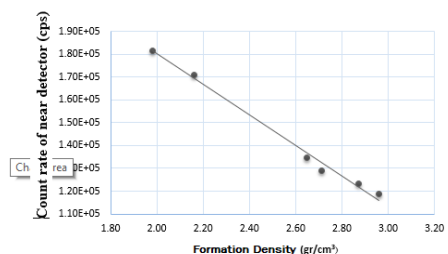
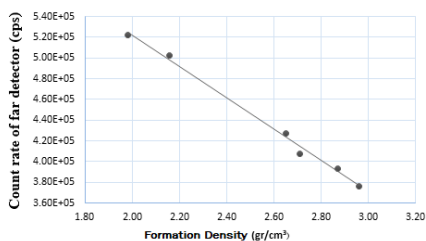
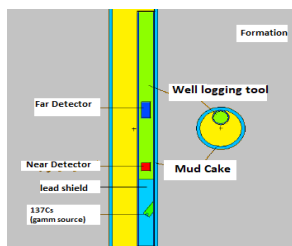

Conceptual design and fabrication of interface level measurement system of unsolvable liquids using gamma method

Client: K. N. Toosi University of Technology

Date: 2012-2014

Project Director: Dr Faezeh Rahmani

Project type: Simulation study

Summary of project:

In this project, conceptual design of prototype liquid interface level measurement system using gamma source has been proposed. All calculations have been performed using MCNPX Monte Carlo simulation code. The activity of ^{137}Cs gamma source is 30 mCi and 2 inch NaI (TI) has been selected. Conical lead shield has been used between source and detector.

Mechanical and electrical system has been designed to achieve a lifting mechanism as well as data gathering system based on scattered gamma and maximum standard deviation of two successive data algorithm. Prototype system has been tested for water and gasoline which show error less than 1 cm in vertical recognition.



Conceptual Design of Neutron-Neutron Logging Tool for determining amount of Porosity and its type in gas bearing Formation

Client: K. N. Toosi University of Technology

Date: 2014-2016

Project Director: Dr Faezeh Rahmani

Project type: Simulation study

Summary of project:

The process of exploration and analysis of hydrocarbon reservoir with good estimation is important.

There are numerous methods of well-logging such as nuclear methods to analyze underground resources. In this project, conceptual design of neutron porosity tool based on MCNPX Monte Carlo methods has been presented. This tool including neutron source ($^{241}\text{Am-Be}$), two sets of neutron detector (two far

detectors with 12.7×2.54 cm in dimension and two near detectors with 7.62×2.54 cm in dimension and 4 mm PE covering), neutron shield (PE, Boron Carbide and lead), electronic system component for data acquisition system. This porosity tool can measure porosity of 40 percent in calcite and sunstone formations and 35 in dolomite with precision better than 5 %.

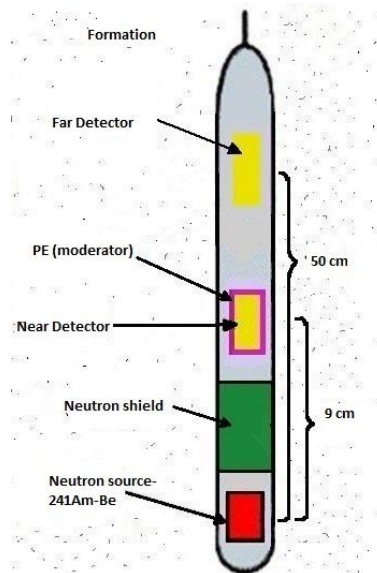

+



Project: On-line leakage detection using radiotracer injection method

Client: K. N. Toosi University of Technology

Date: 2012-2014

Project Director: Dr Faezeh Rahmani

Project type: Simulation study

Summary of project:

One of the most important requirements for industrial pipelines is the leakage detection. In this project, detection of leak and determination of its amount using radioactive tracer injection method has been simulated by Monte Carlo MCNP code. The detector array included two NaI (TI) detectors which were located before and after the considered position, measure emitted gamma from radioactive tracer. Also, the effect of material and thickness of

pipe, activity of tracer and its type (24Na, 82Br, 131I, 99mTc, and 113mIn) as well as types of fluid have been investigated on the detectable amount of leakage. According to the results, leakages more than 0.007% in volume of the inlet fluid (iron pipe with Outlet Diameter 4 inch and thickness of 0.5 cm, Petrol as fluid inside pipe, 3×3 inch detector, and 24Na with activity of 100 mCi) can be measured by this presented method.

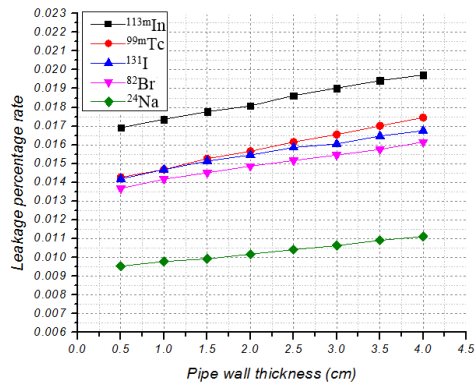
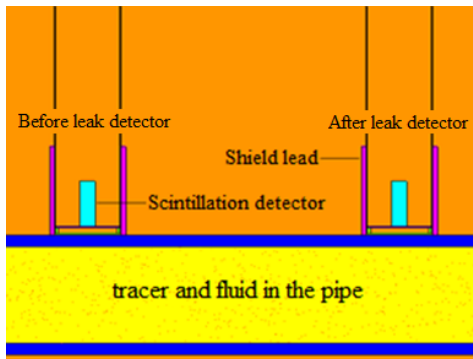

Development, design and implementation of a software tool to simulate cathodic protection system on pipeline networks

Client: National Iranian Gas Company

Date: 2011-2018

Project Director: Dr Morteza Behbahani-Nejad (Shahid Chamran University)

Project associate members: Dr. Farschad Torabi (K. N. Toosi University of Technology), Dr. Maziar Changizian (Shahid Chamran University), Dr. Ali Ashrafi (Isfahan University of Technology)

Project type: Software Development, Database generation

Project collaborator: Shahid Chamran University, K.N. Toosi University of Technology & Isfahan University of Technology

Summary of project:

Due to the important role of efficient and reliable Cathodic Protection System, the Iranian National Gas Company delineated and signed a contract with Shahid Chamran University of Ahvaz to perform a research project on the development, design and implementation of a software tool to simulate cathodic protection system on pipeline networks. The key objectives of the project include:

- A powerful software tool for simulating cathodic protection

systems for huge pipeline networks

- Rich Database established on field and laboratory data mining
- Dynamic and three-dimensional graphical environment
- Provides the distribution of the on and off potential, the axial current and the voltage along the entire network with the help of colored contours

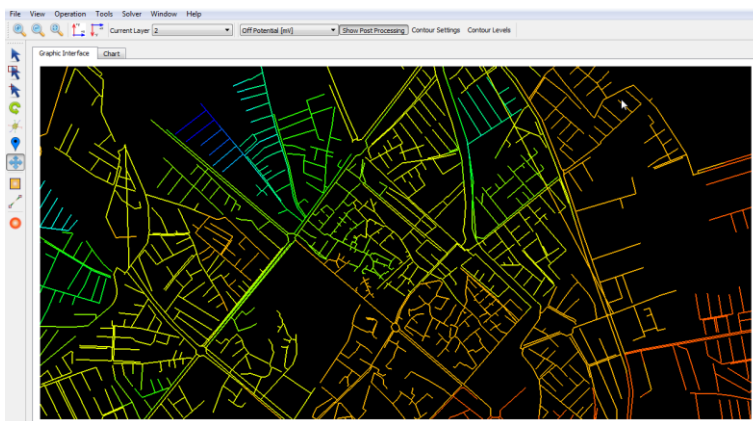

Off Potential [mV]	
1	
1	-750
2	-790
3	-830
4	-870
5	-910
6	-950
7	-990
8	-1030
9	-1070
10	-1110
11	-1150

Ten micron-thick undoped SnO₂ layers grown by spray pyrolysis for microheater fabrication

Client: Exciton Company

Date: 2013-2017

Project Director: Prof. Faramarz Hossein-Babaei

Project associate members: Mohsen Gharesi, Mohammad Ansari

Project type: Pilot plant implementation

Project Collaborator: K. N. Toosi University of Technology

Summary of project:

Micro-thick layers of tin oxide are advantageous for the fabrication of high power density transparent microheaters operating at elevated temperatures and harsh environs. In this project, 10 μm -thick SnO₂ layers are grown on alumina substrates through ultrasonic spray pyrolysis deposition. Produced layers function as long life heating elements operating at temperatures as high as 1000 °C. The required ohmic contacts are formed through diffusion bonding of gold wires to the SnO₂ deposits. Long term stability of the fabricated microheaters is examined in a month of continuous operation at 600 °C; the

devices show only ~5% surface temperature change, demonstrating exceptional high temperature stability of the tin oxide microheaters. The thermal stability of the composition and microstructure, the negative temperature coefficient of resistance, and the proper range of sheet resistance, render the grown layers suitable for long life microheater fabrication. The device is utilized as low voltage fuel igniter in exhaust systems for combustion safety units in chemical and petrochemical reactors. It is also used for providing the elevated temperatures required for the operation of the resistive methane sensors.

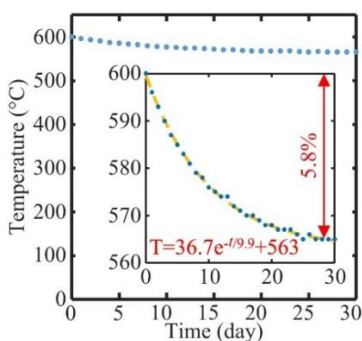

Long-term performance of a tin oxide microheater.

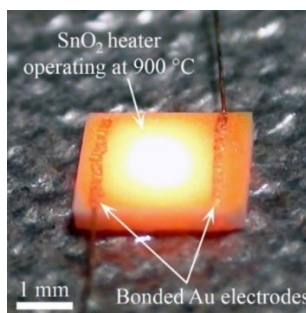

Photograph of a tin oxide microheater.

K. N. Toosi University of Technology

is a public, higher educational institution in Tehran, Iran. The university was founded in 1928. With more than 300 full-time faculty members and 7200 students, K. N. Toosi University of technology is known for its excellent track record of research activities and industrial projects. K. N. Toosi University of Technology is committed to being an internationally recognized university by advancing knowledge through research and educating students in science, technology, and other areas of scholarship that will best serve the country and the world. K. N. Toosi University of Technology is determined to provide its students, faculty, and staff with the best possible resources and conditions for learning and research, and to create a respectful and nurturing, yet challenging work environment. It will cooperate with the community, other educational institutions, and the industry to discover and apply new knowledge and technologies. It is committed to preparing its students for fulfilling careers and improving the quality of life through leading-edge research and unrelenting innovation.



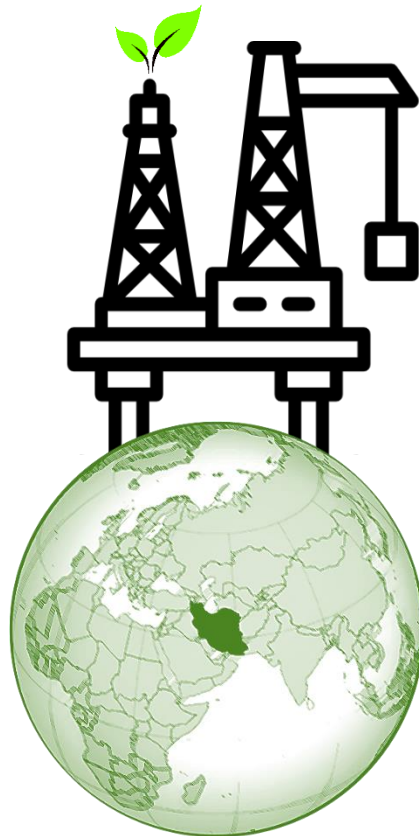

www.PIPRC.kntu.ac.ir

PIPRC Petroleum Industry Productivity Research Center

K.N. Toosi University of Technology.

Iran, Tehran Province, Tehran, Mirdamad Blvd, No. 470

Tel: +98(21)88881002, Fax: +98(21)88882997

Email: piprc@kntu.ac.ir

